



Rettungsdatenblätter

3

- 350Z Coupé Z33 2002-2009
- 350Z Cabriolet Z33 2003-2009
- 370Z Coupé Z34 2009-
- 370Z Cabriolet Z34 2009-

A

- ALMERA 3-Türer N16 1995-2007
- ALMERA 4-Türer N16 1995-2007
- ALMERA 5-Türer N16 1995-2007
- ALMERA TINO V10 2000-2006

C

- CUBE Z12 2010-2011

E

- e-NV200 ME0M 2014-
- EVALIA M20M 2011-

G

- GT-R R35 2008-

I

- INTERSTAR X70 2004-2010

J

- JUKE F15 2010-

L

- LEAF ZE0 2011-2013
- LEAF ZE0 2013-2017
- LEAF ZE1 2017-

M

- MICRA 3-Türer K11 1996-2003
- MICRA 5-Türer K11 1996-2003
- MICRA 3-Türer K12 2003-2010
- MICRA 5-Türer K12 2003-2010
- MICRA C+C K12 2005-2009
- MICRA 5-Türer K13 2010-2017
- MICRA 5-Türer K14 2017-
- MURANO Z50 2005-2008
- MURANO Z51 2008-

N

- NAVARA King Cab D40 2005-2015
- NAVARA Crew Cab D40 2005-2015
- NAVARA King Cab D23 2015-
- NAVARA Crew Cab D23 2015-
- NOTE E11 2006-2013
- NOTE E12 2013-
- NP300 Single Cab D22 2008-2011
- NP300 King Cab D22 2008-2011
- NP300 Crew Cab D22 2008-2011
- NT400 CABSTAR F24 2006-
- NV200 M20 2009-
- NV250 L1 W 2019-
- NV250 L2 W 2019-
- NV300 X82 2016-
- NV400 M9 2011-

P

- PATHFINDER R51 2005-
- PATROL 3-Türer Y61 2000-2009
- PATROL 5-Türer Y61 2000-2009
- PIXO UA0 2009-2013
- PRIMASTAR X83 2003-
- PRIMERA 4-Türer P11 1994-2002
- PRIMERA 5-Türer P11 1994-2002
- PRIMERA Kombi P11 1994-2002
- PRIMERA 4-Türer P12 2002-2008
- PRIMERA 5-Türer P12 2002-2008
- PRIMERA Kombi P12 2002-2008
- PULSAR C13 2014-

Q

- QASHQAI J10 2007-2014
- QASHQAI+2 J10 2008-2014
- QASHQAI J11 2014-

T

- TIIDA C11 2006-2011

X

- X-TRAIL T30 2001-2007
- X-TRAIL T31 2007-2014
- X-TRAIL T32 2014-







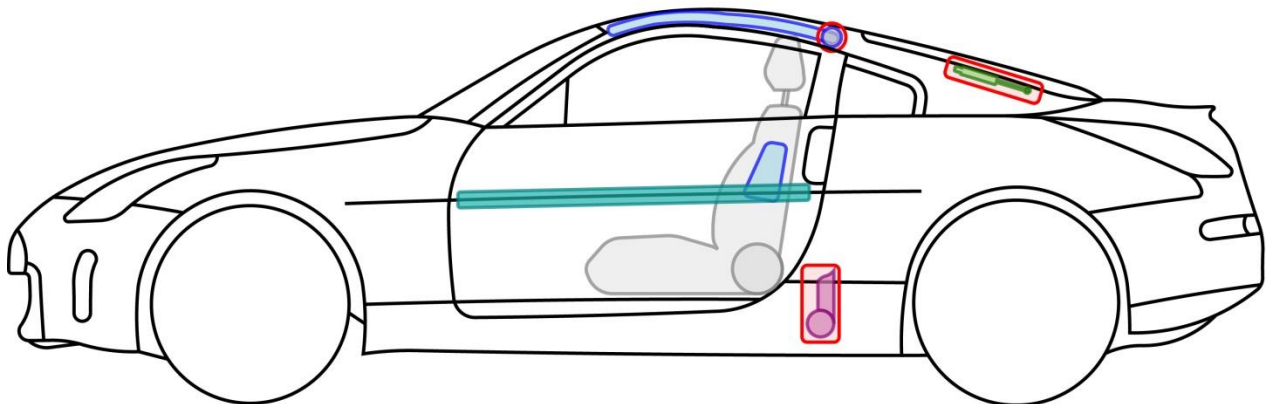
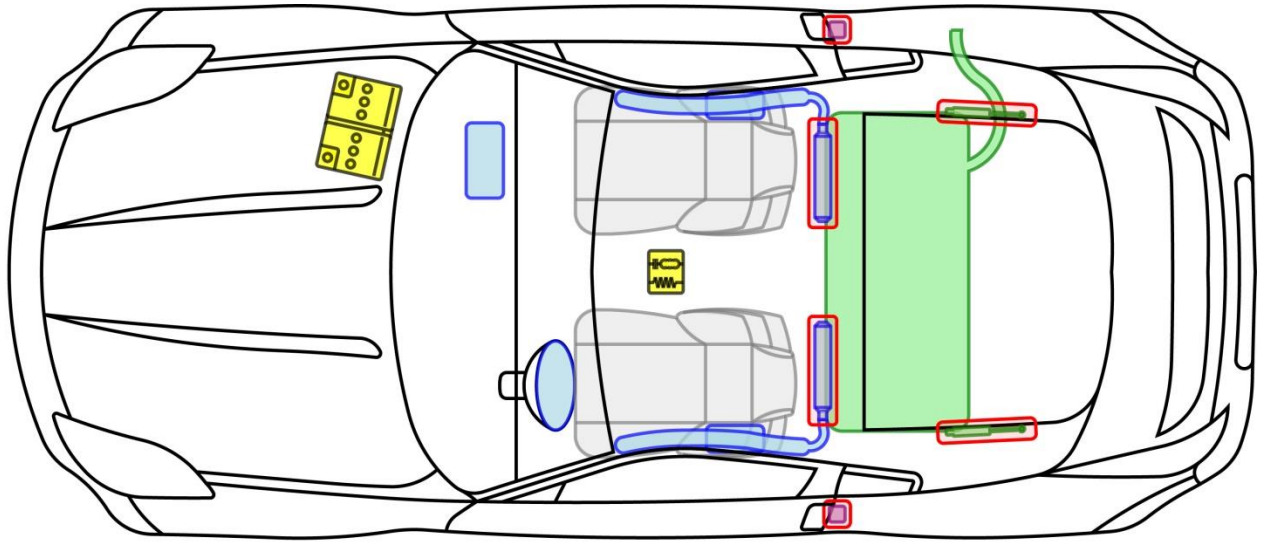

350Z Coupé

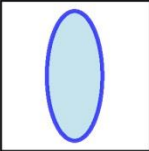
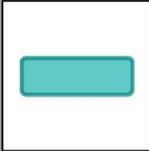
Typ: Z33, 2002-2009

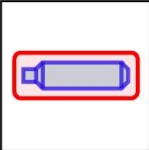

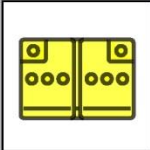
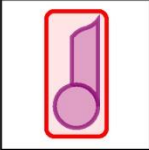
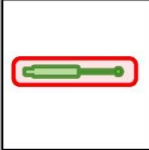
Legende

| | | | | | |
|---|-------------------|---|----------------------------|--|---------------------|
|  | Airbag |  | Karosserie- verstärkung |  | Steuergerät |
|  | Gas- generator |  | Überroll- schutz |  | Batterie |
|  | Gurt- straffer |  | Gasdruck- dämpfer |  | Kraftstoff- tank |

350Z







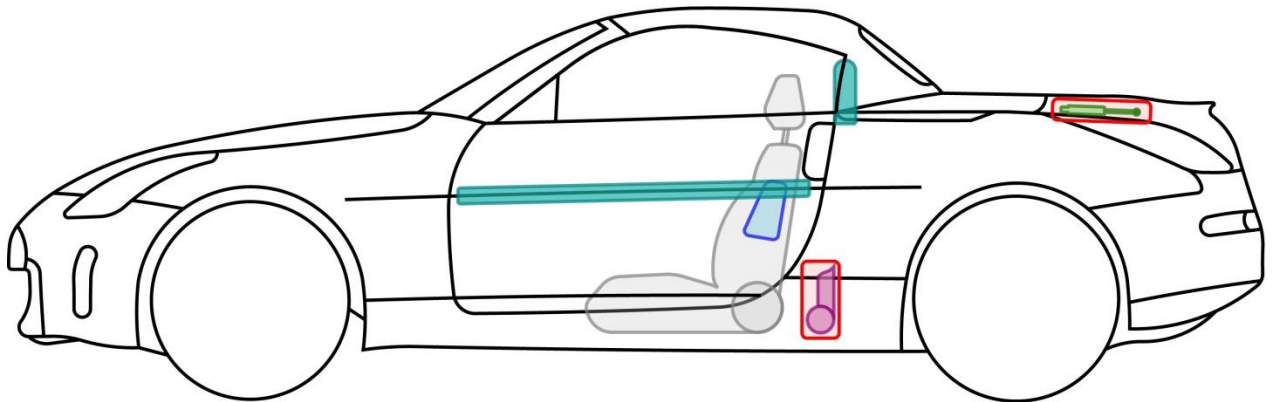
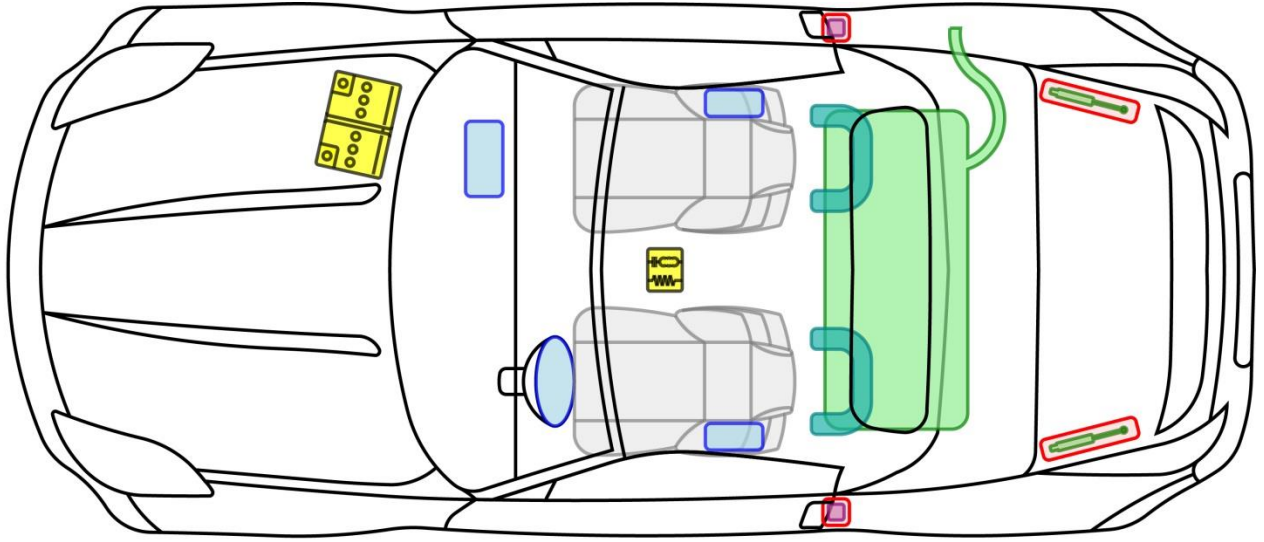

350Z Cabriolet

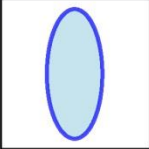
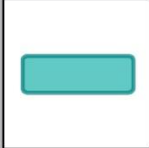
Typ: Z33, 2003-2009

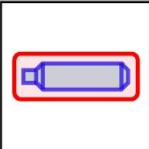

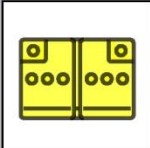
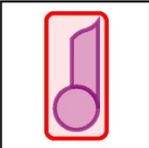
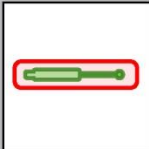
Legende

| | | | | | |
|---|-------------------|---|----------------------------|--|---------------------|
|  | Airbag |  | Karosserie- verstärkung |  | Steuergerät |
|  | Gas- generator |  | Überroll- schutz |  | Batterie |
|  | Gurt- straffer |  | Gasdruck- dämpfer |  | Kraftstoff- tank |

350Z







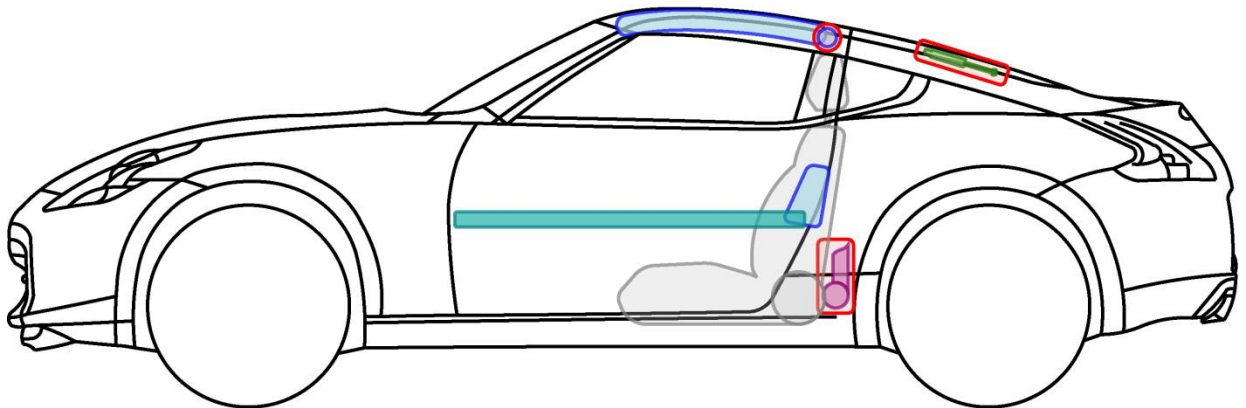
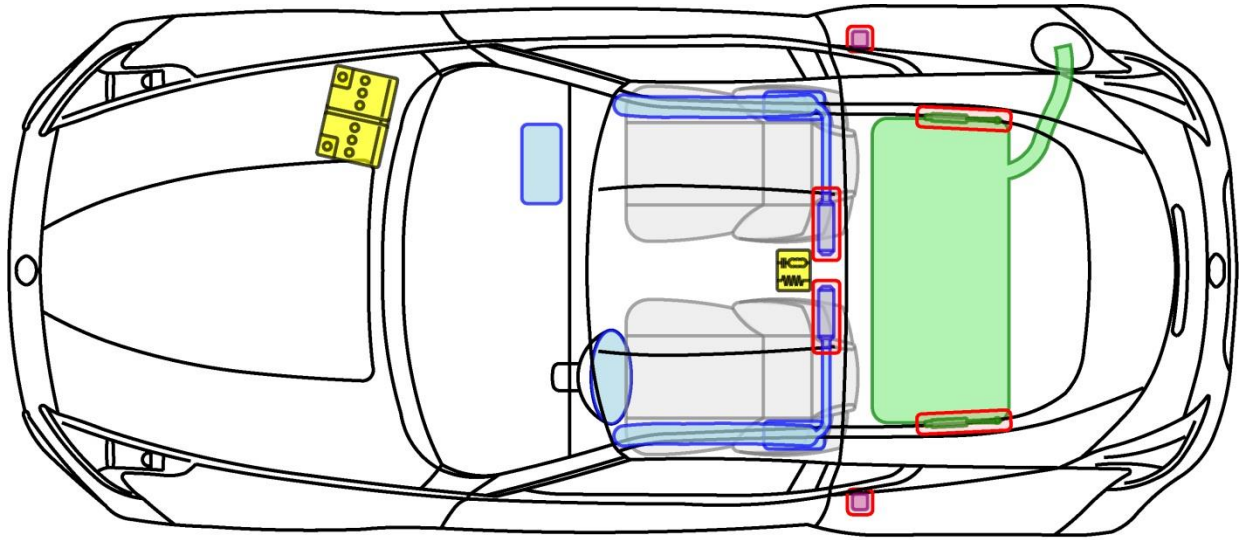

370Z Coupé

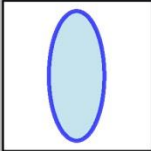
Typ: Z34, 2009-

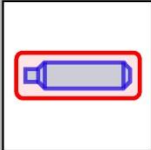

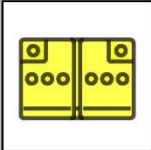
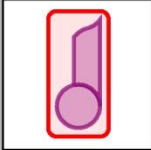
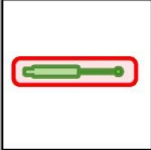
Legende

| | | | | | |
|---|-------------------|---|----------------------------|--|---------------------|
|  | Airbag |  | Karosserie- verstärkung |  | Steuergerät |
|  | Gas- generator |  | Überroll- schutz |  | Batterie |
|  | Gurt- straffer |  | Gasdruck- dämpfer |  | Kraftstoff- tank |

370Z







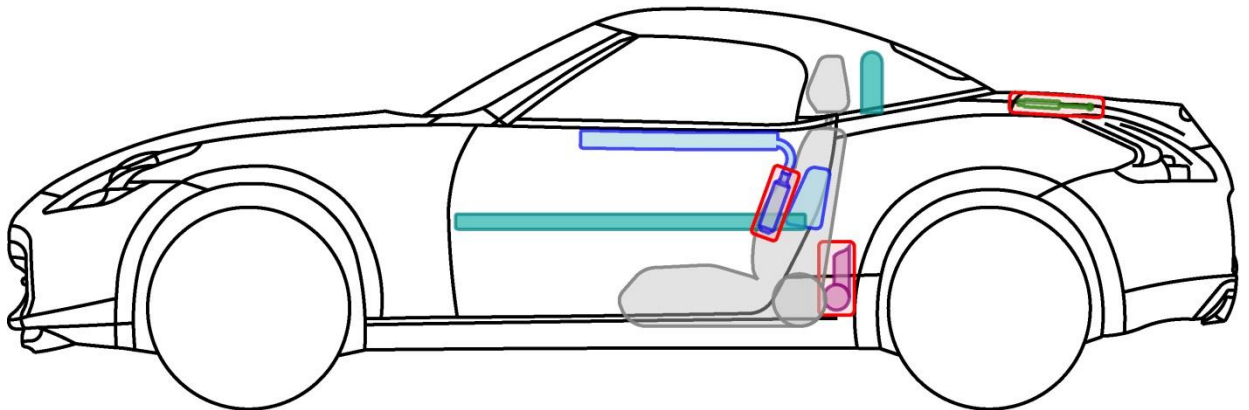
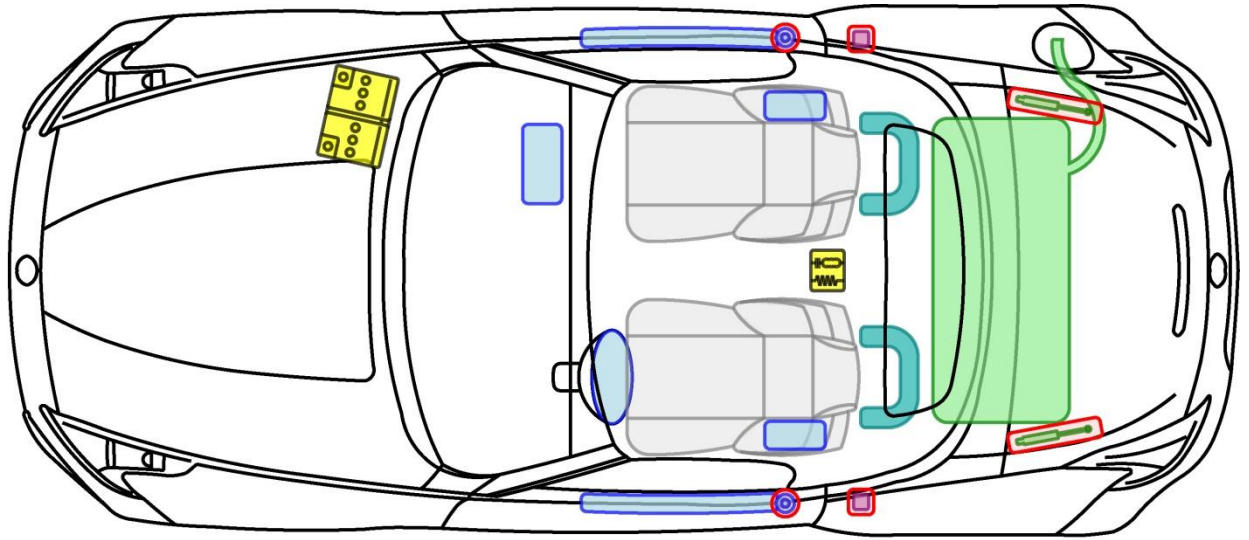

370Z Cabriolet

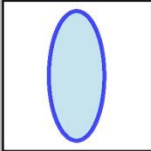
Typ: Z34, 2010-

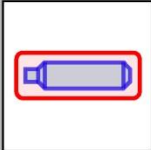

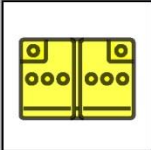
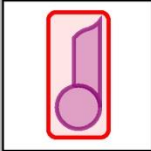
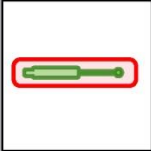
Legende

| | | | | | |
|---|-------------------|---|----------------------------|--|---------------------|
|  | Airbag |  | Karosserie- verstärkung |  | Steuergerät |
|  | Gas- generator |  | Überroll- schutz |  | Batterie |
|  | Gurt- straffer |  | Gasdruck- dämpfer |  | Kraftstoff- tank |

370Z



ALMERA 3-Türer

Typ: N16, 1995-2007

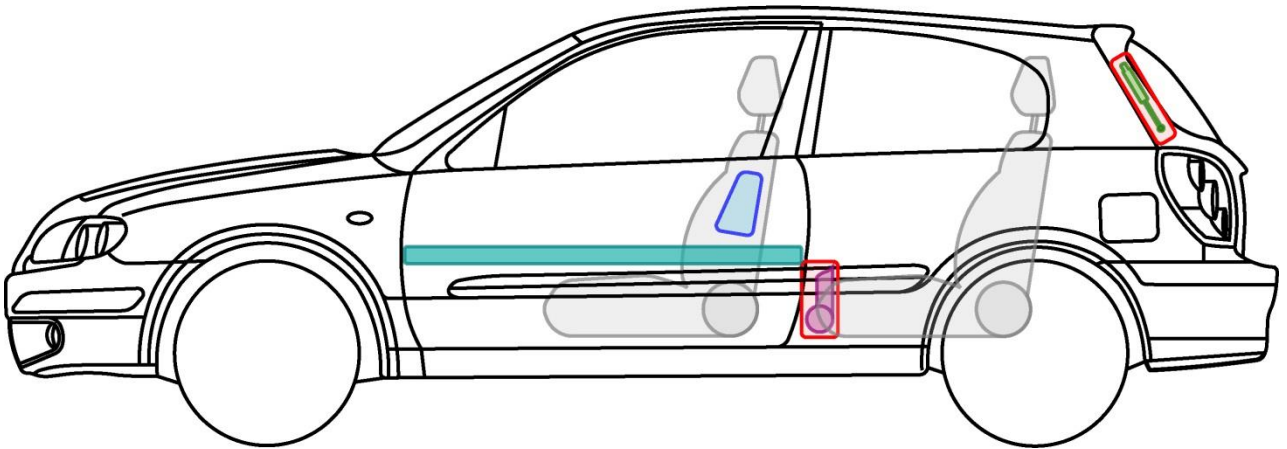
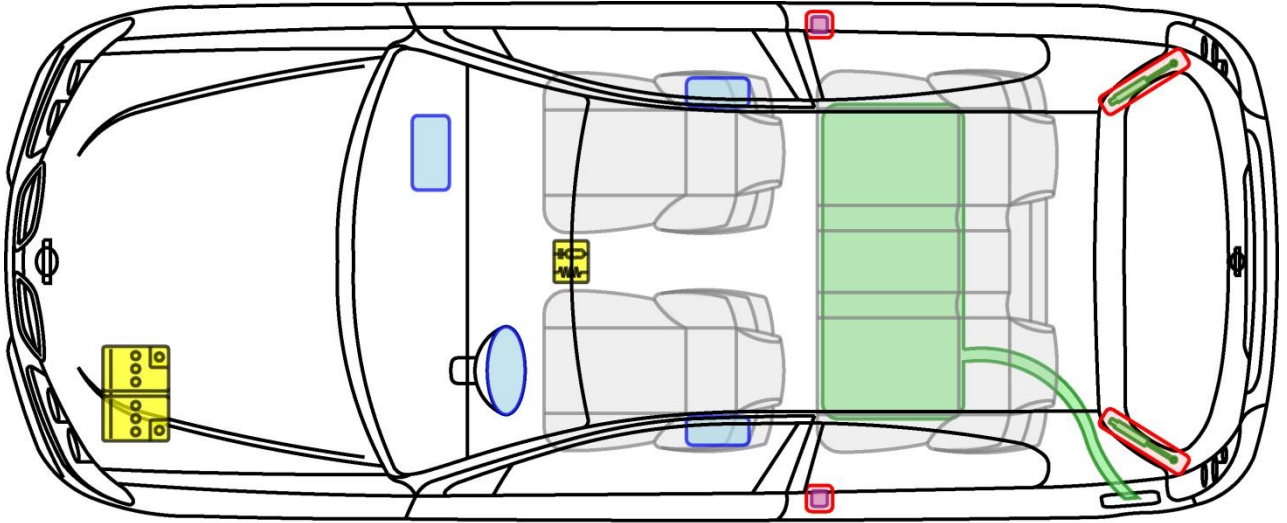

Legende

| | | | | | |
|--|-------------------|--|----------------------------|--|---------------------|
| | Airbag | | Karosserie- verstärkung | | Steuergerät |
| | Gas- generator | | Überroll- schutz | | Batterie |
| | Gurt- straffer | | Gasdruck- dämpfer | | Kraftstoff- tank |

ALMERA







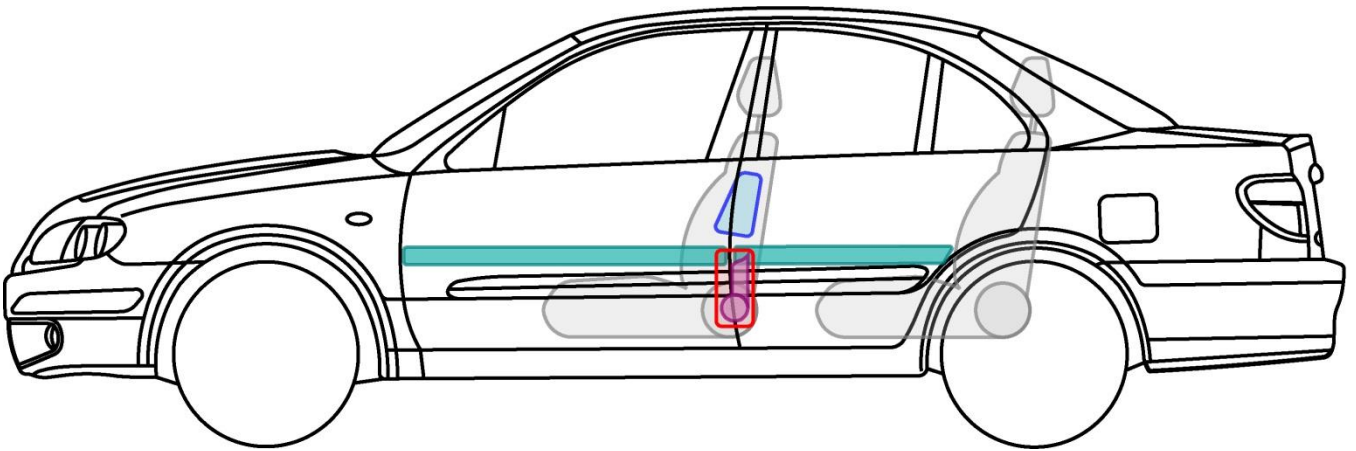
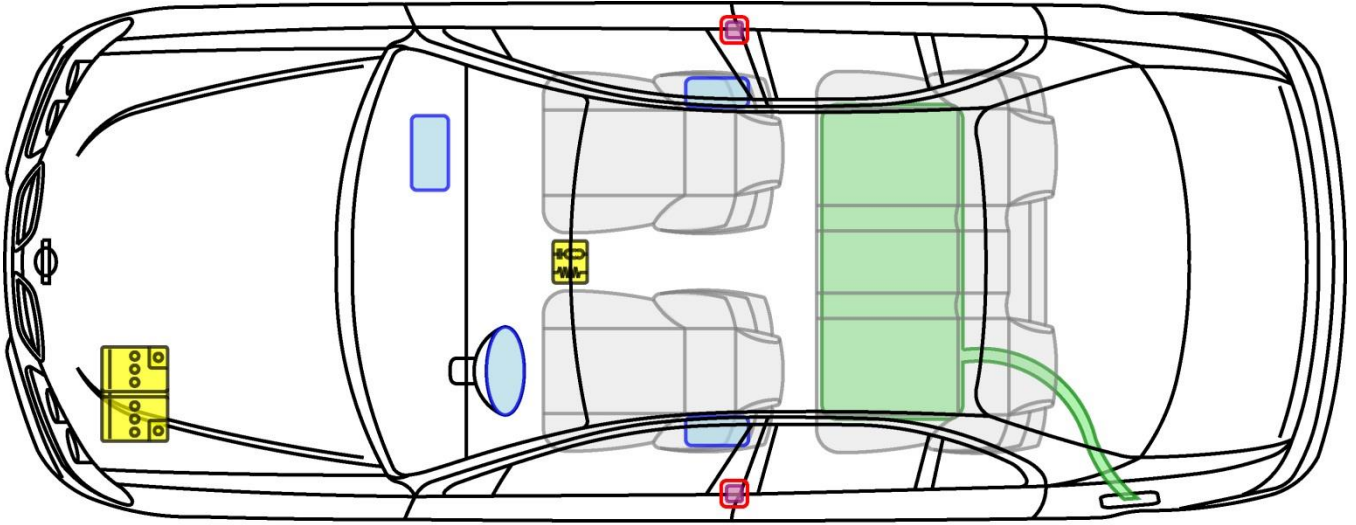

ALMERA 4-Türer

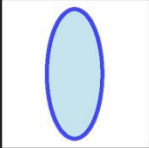
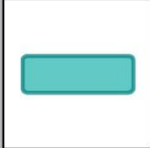
Typ: N16, 1995-2007

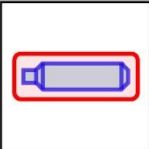

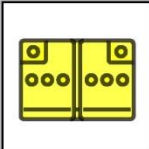
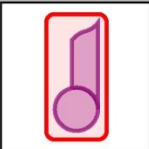
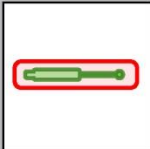
Legende

| | | | | | |
|---|-------------------|---|----------------------------|--|---------------------|
|  | Airbag |  | Karosserie- verstärkung |  | Steuergerät |
|  | Gas- generator |  | Überroll- schutz |  | Batterie |
|  | Gurt- straffer |  | Gasdruck- dämpfer |  | Kraftstoff- tank |

ALMERA







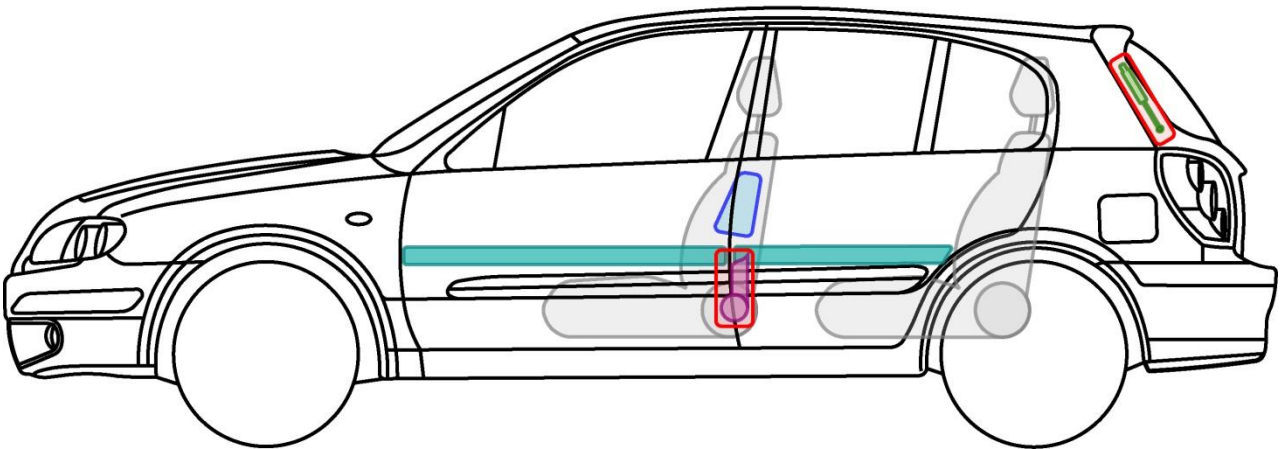
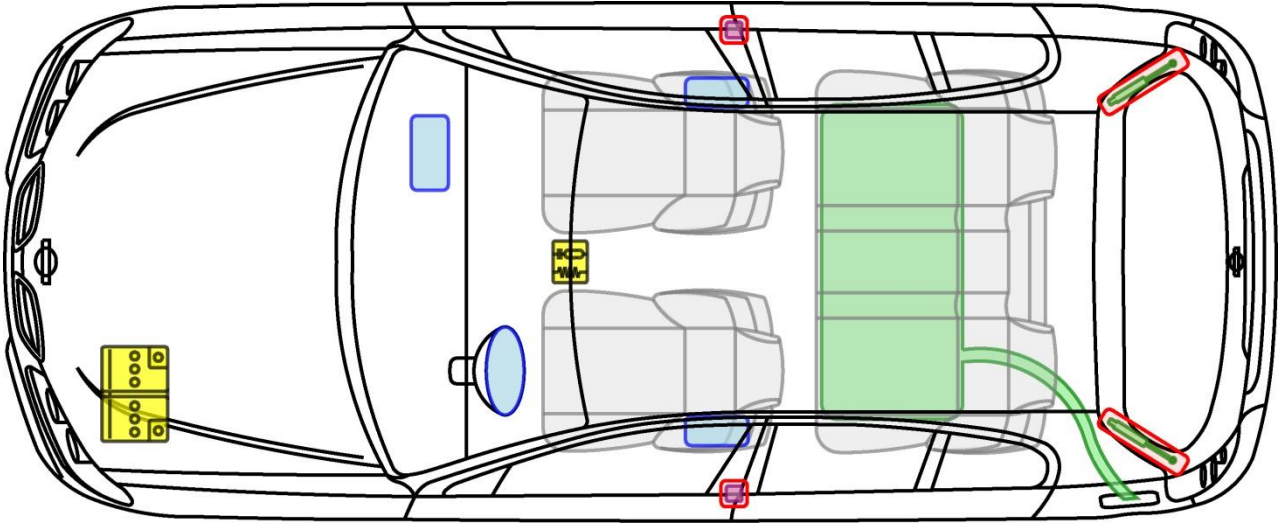

ALMERA 5-Türer

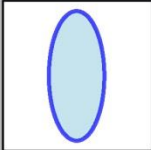
Typ: N16, 1995-2007

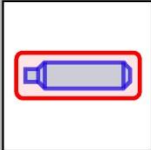

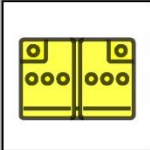
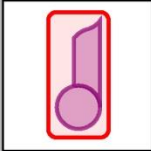
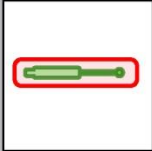
Legende

| | | | | | |
|---|-------------------|---|----------------------------|--|---------------------|
|  | Airbag |  | Karosserie- verstärkung |  | Steuergerät |
|  | Gas- generator |  | Überroll- schutz |  | Batterie |
|  | Gurt- straffer |  | Gasdruck- dämpfer |  | Kraftstoff- tank |

ALMERA







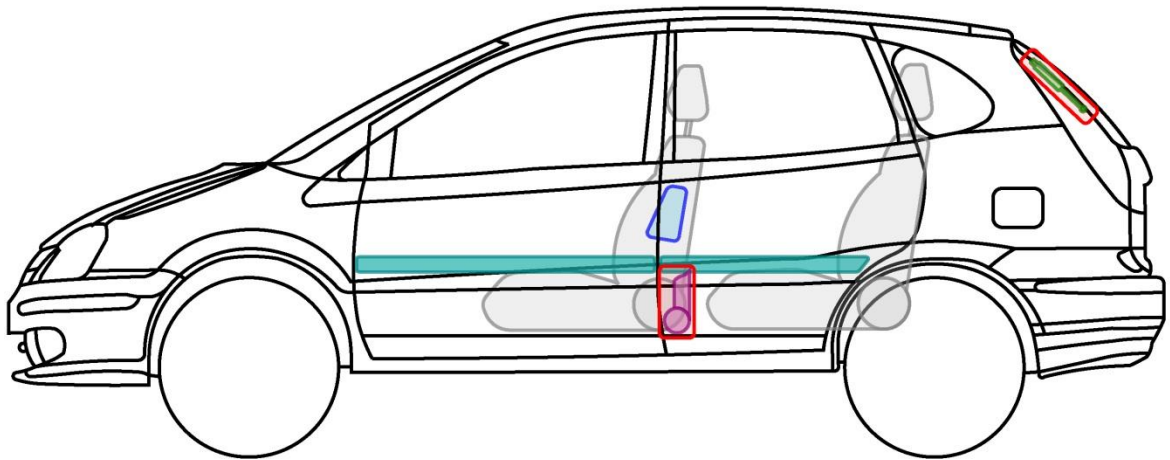
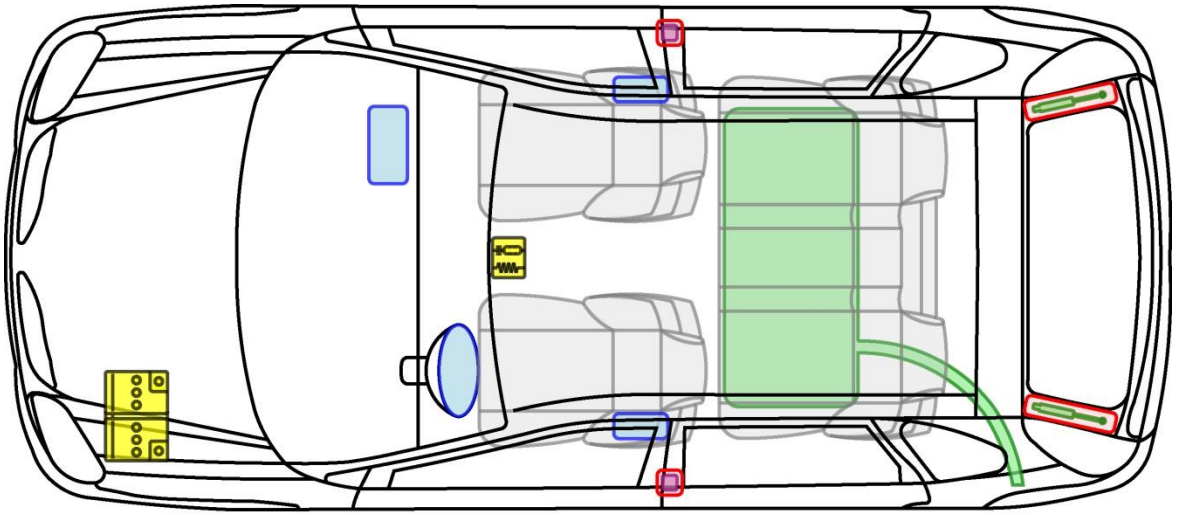

ALMERA TINO

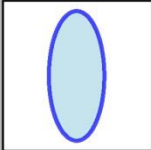
Typ: V10, 2000-2006

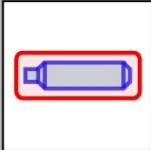

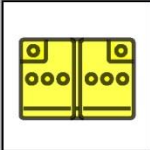
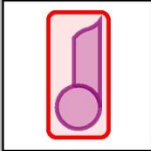
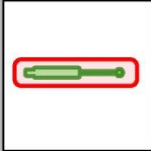
Legende

| | | | | | |
|---|-------------------|---|----------------------------|--|---------------------|
|  | Airbag |  | Karosserie- verstärkung |  | Steuergerät |
|  | Gas- generator |  | Überroll- schutz |  | Batterie |
|  | Gurt- straffer |  | Gasdruck- dämpfer |  | Kraftstoff- tank |

ALMERA TINO



CUBE

Typ: Z12, 2010-2011

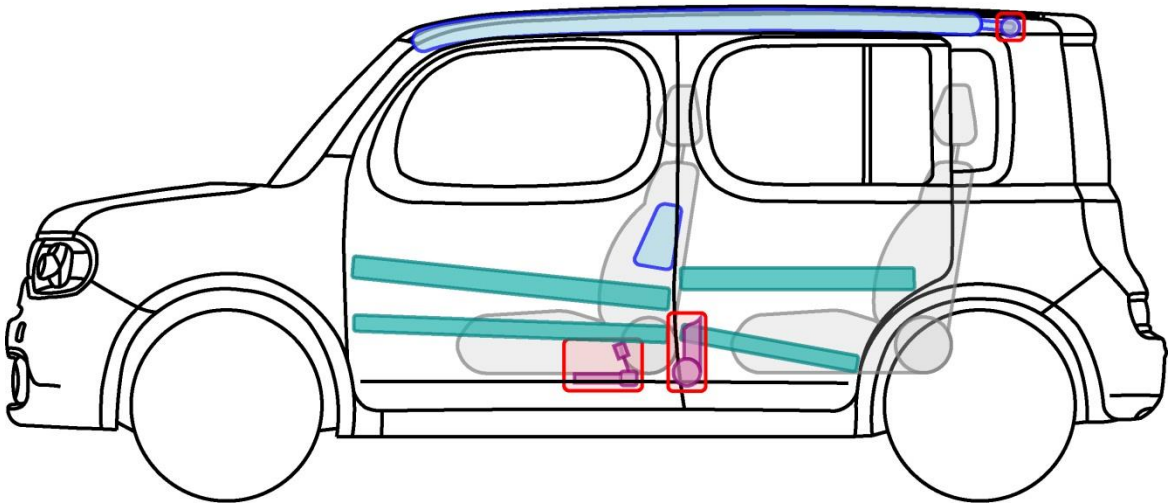
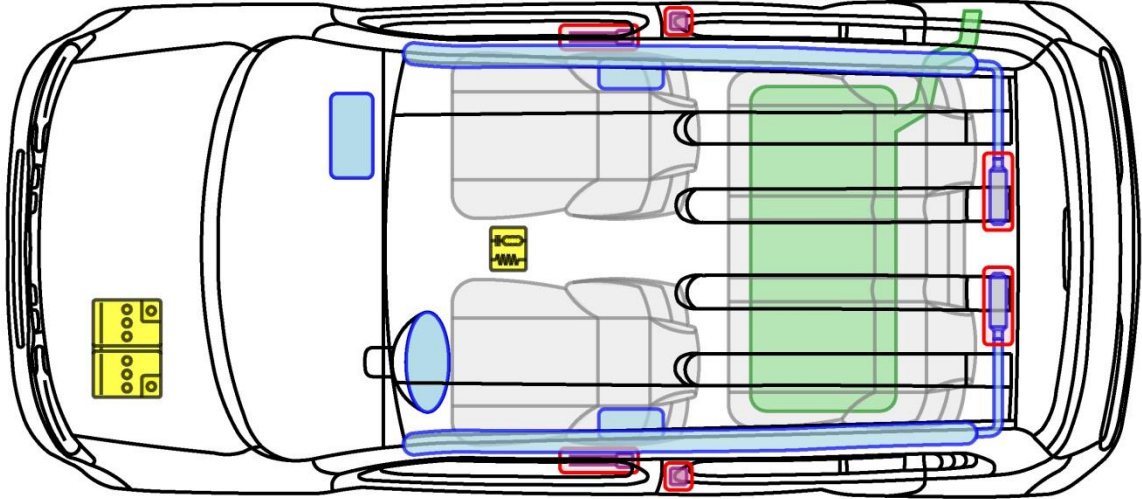

Legende

| | | | | | |
|--|-------------------|--|----------------------------|--|---------------------|
| | Airbag | | Karosserie- verstärkung | | Steuergerät |
| | Gas- generator | | Überroll- schutz | | Batterie |
| | Gurt- straffer | | Gasdruck- dämpfer | | Kraftstoff- tank |





e-NV200

Typ: ME0M, 2014-

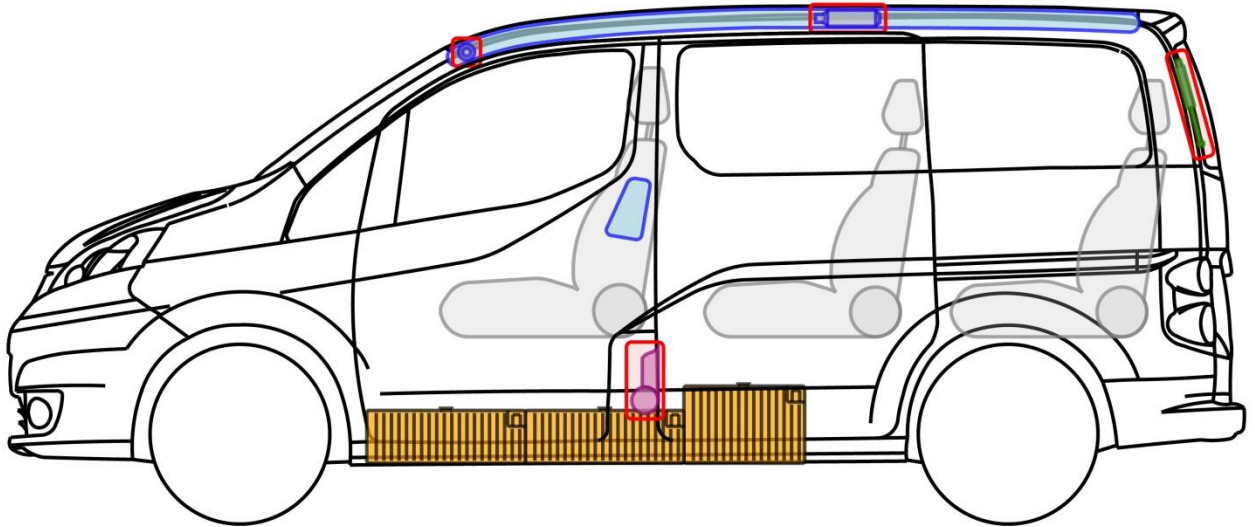
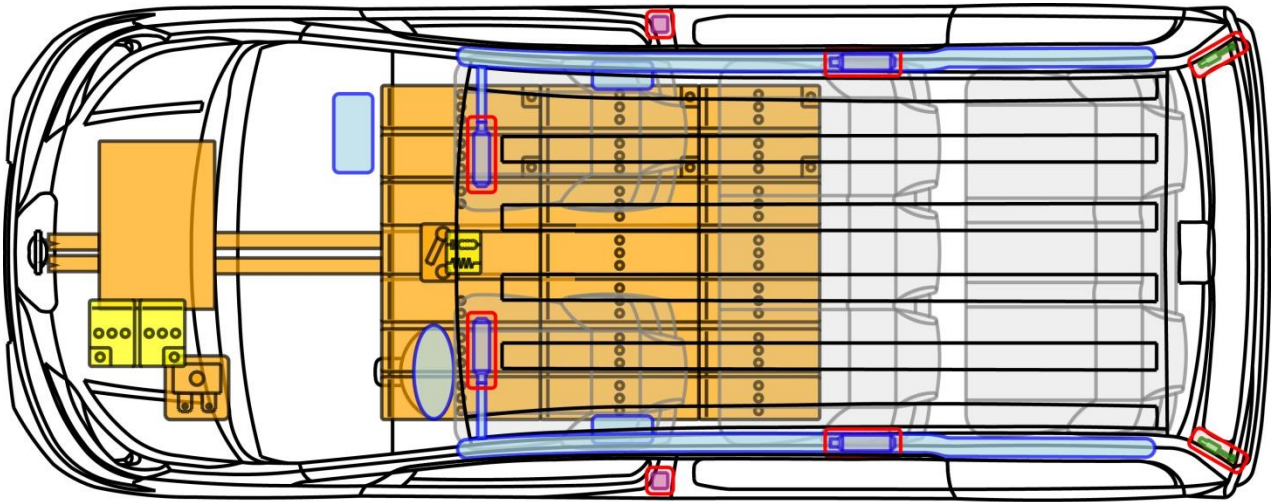

Legende

| | | | | | | | |
|--|----------------|--|-----------------------|--|-------------------|--|------------------------------|
| | Airbag | | Karosserieverstärkung | | Steuergerät | | Hochvolt-leitung/-komponente |
| | Gas-generator | | Überrollschutz | | 12 V Batterie | | HV-Trennstelle |
| | Gurtstraffer | | Gasdruckdämpfer | | Hochvolt-batterie | | Sicherungskasten |
| | Kraftstofftank | | | | | | |

e-NV200



e-NV200

Typ: ME0M, 2014-



Allgemeine Hinweise

- Bei Unfällen mit Airbag und/oder Gurtstrafferauslösung wird der Fahrzeugantrieb automatisch deaktiviert. Die Rückhaltesysteme sind weiterhin aktiv.
- Die Zeit bis zur vollständigen Deaktivierung des Antriebs beträgt **10 Minuten** nach Durchführung der Deaktivierungsschritte.
- **Vor Beginn von Arbeiten am Fahrzeug Ladestecker ziehen!**
- **Schutzausrüstung erforderlich (Isolierende Handschuhe bis 1000 V, Gesichtsschutz).**

Fahrzeug gegen wegrollen sichern

- Räder unterkeilen.
- Feststellbremse betätigen.

Deaktivieren von Hochvolt- (HV) und Rückhaltesystem (SRS)

Methode 1

1. Prüfen ob das Hochvoltsystem eingeschaltet ist. Symbol: 
2. Ist das System aktiv, Start-Stopp Knopf einmal betätigen.
3. 12 Volt Batterie abklemmen. Massekabel zuerst.





e-NV200

Typ: ME0M, 2014-



Deaktivieren von Hochvolt- (HV) und Rückhaltesystem (SRS)

Methode 2

1. Sicherungskasten lokalisieren und öffnen.



2. Dargestellte Sicherungen entfernen.



1. 12 Volt Batterie abklemmen. Massekabel zuerst.





e-NV200

Typ: ME0M, 2014-



Deaktivierung des Hochvoltsystem (HV)

Methode 3

1. HV-Trennstelle lokalisieren, Abdeckung entfernen.
2. Verkleidungsteil abschrauben und nach oben abheben.
3. Abdeckung öffnen, z.B. durch Abschrauben (Schlüsselweite 10 mm) oder aufhebeln.
4. Servicestecker wie dargestellt entfernen!
Schutzausrüstung erforderlich (Isolierende Handschuhe bis 1000 V, Gesichtsschutz).

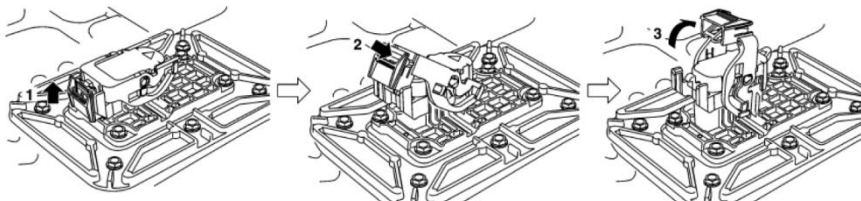
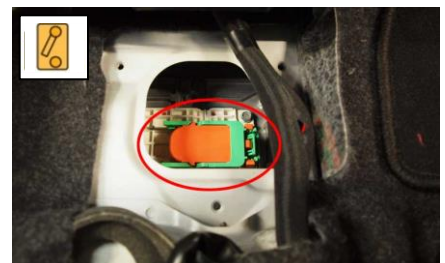

- **Kann die 12 Volt Batterie nicht abgeklemmt werden, sind die Rückhaltesysteme weiterhin aktiv!**



EVALIA

Typ: M20M, 2011-

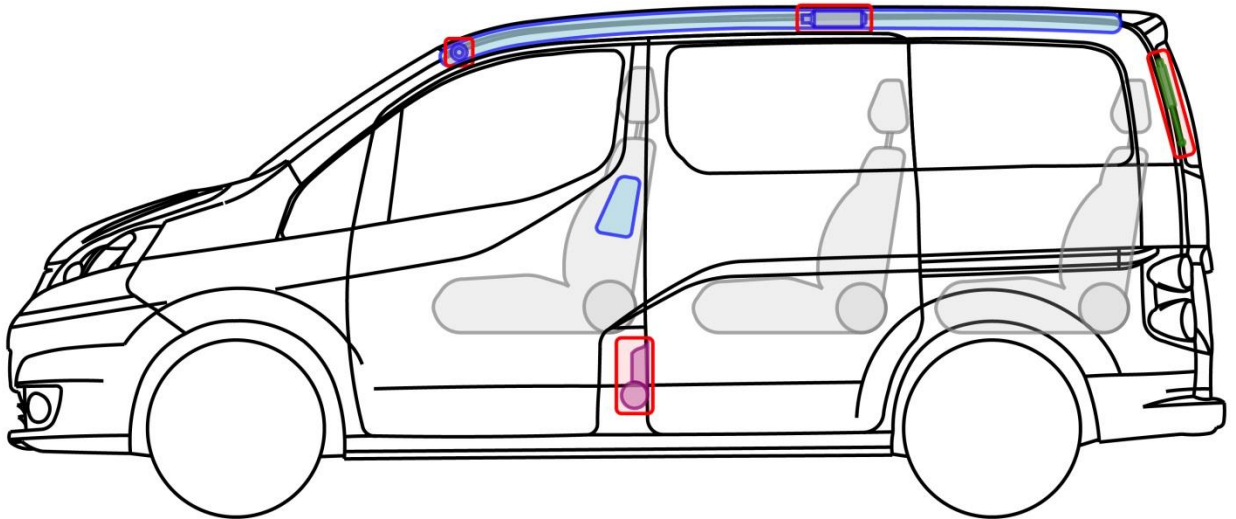
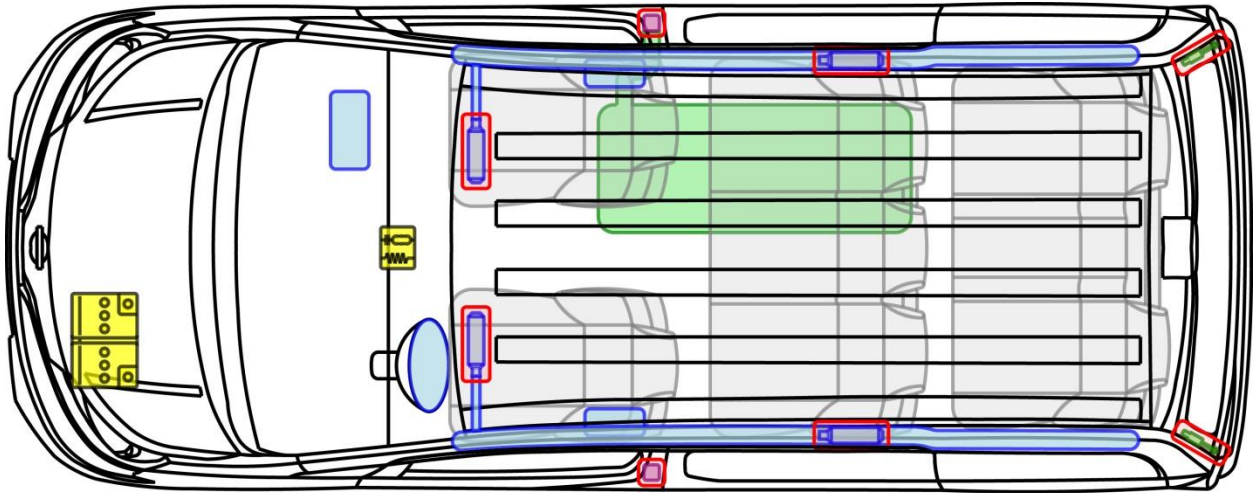

Legende

| | | | | | |
|--|-------------------|--|----------------------------|--|---------------------|
| | Airbag | | Karosserie- verstärkung | | Steuergerät |
| | Gas- generator | | Überroll- schutz | | Batterie |
| | Gurt- straffer | | Gasdruck- dämpfer | | Kraftstoff- tank |





GT-R

Typ: R35, 2008-

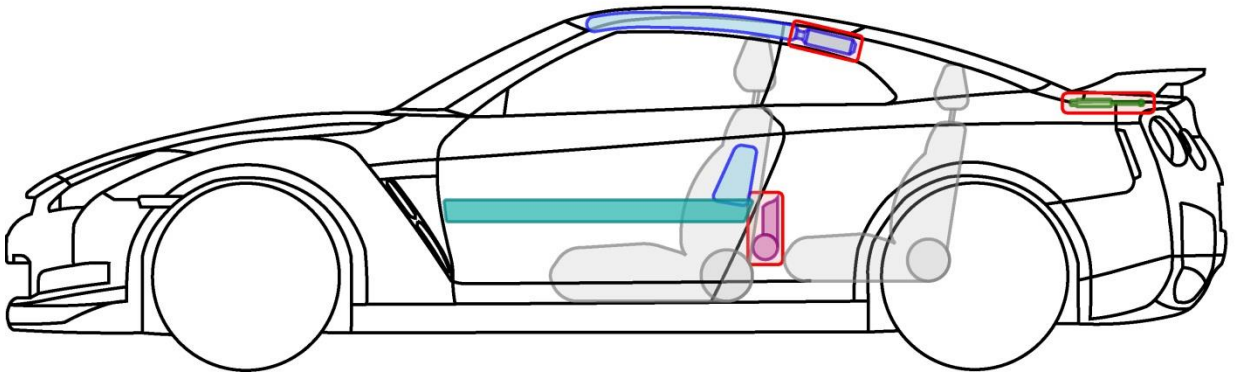
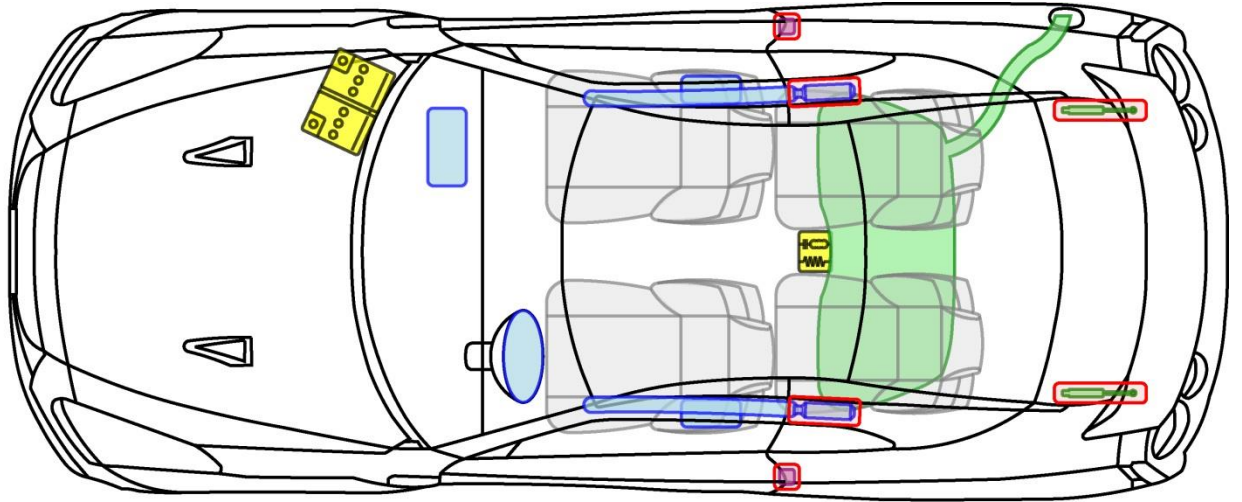

Legende

| | | | | | |
|--|-------------------|--|----------------------------|--|---------------------|
| | Airbag | | Karosserie- verstärkung | | Steuergerät |
| | Gas- generator | | Überroll- schutz | | Batterie |
| | Gurt- straffer | | Gasdruck- dämpfer | | Kraftstoff- tank |

GT-R







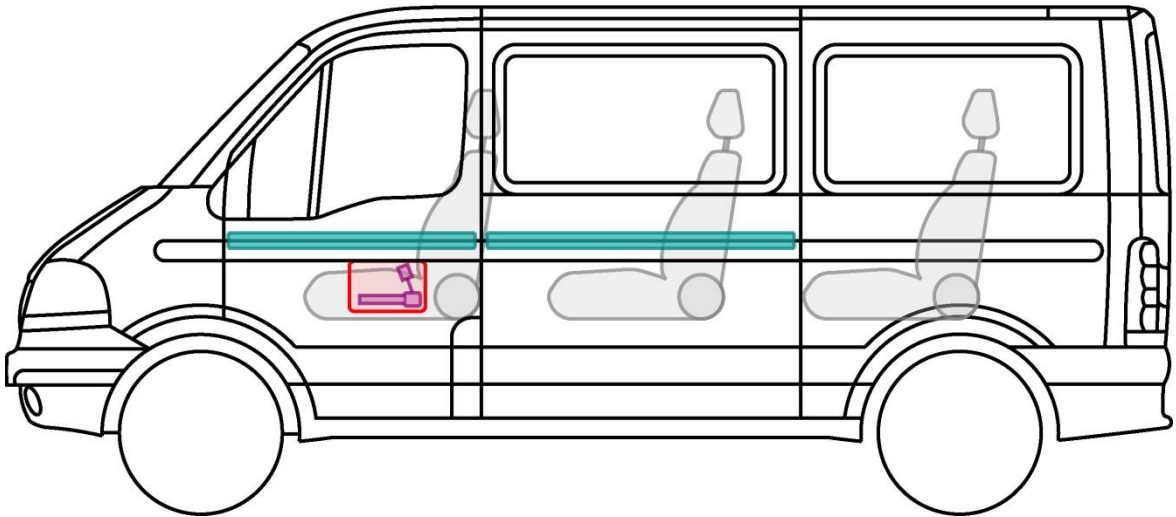
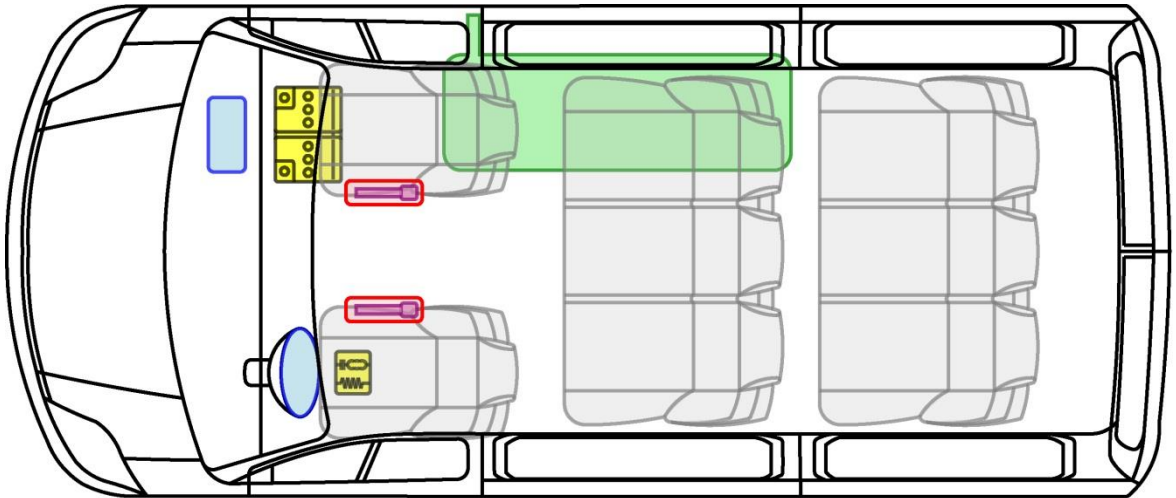

INTERSTAR

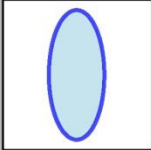
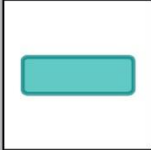
Typ: X70, 2004-2010

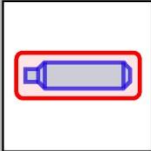

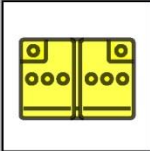
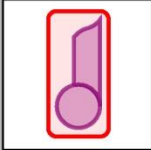
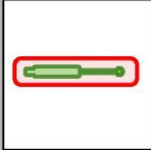
Legende

| | | | | | |
|---|-------------------|---|----------------------------|--|---------------------|
|  | Airbag |  | Karosserie- verstärkung |  | Steuergerät |
|  | Gas- generator |  | Überroll- schutz |  | Batterie |
|  | Gurt- straffer |  | Gasdruck- dämpfer |  | Kraftstoff- tank |

INTERSTAR







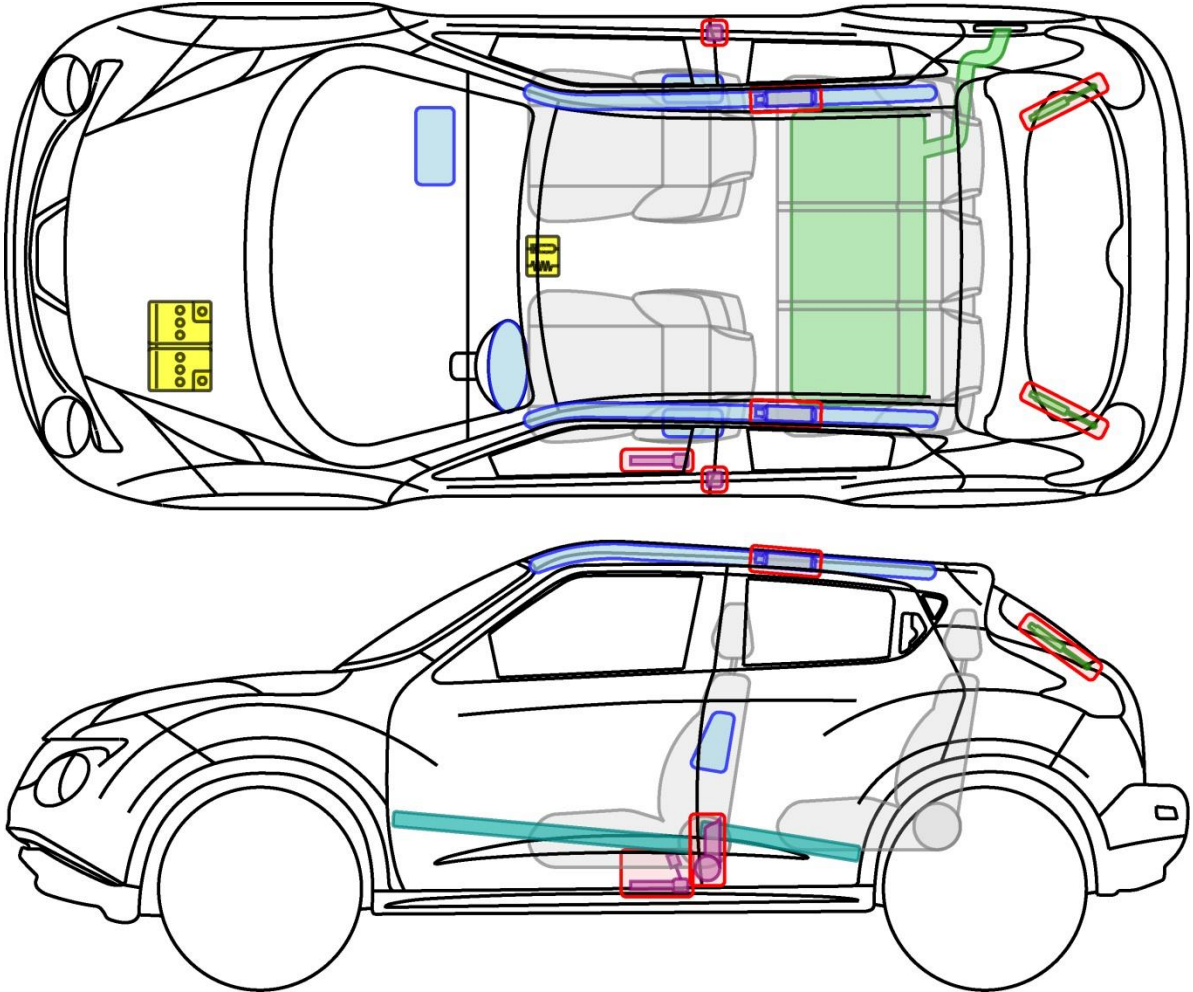

JUKE

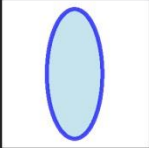
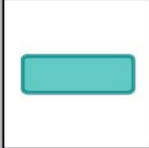
Typ: F15, 2010-

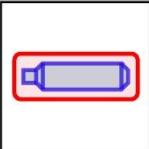

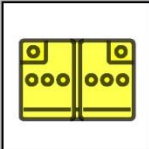
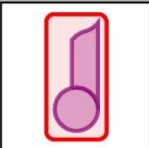
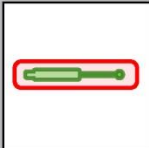
Legende

| | | | | | |
|---|-------------------|---|----------------------------|--|---------------------|
|  | Airbag |  | Karosserie- verstärkung |  | Steuergerät |
|  | Gas- generator |  | Überroll- schutz |  | Batterie |
|  | Gurt- straffer |  | Gasdruck- dämpfer |  | Kraftstoff- tank |





LEAF

Typ: ZE0, 2011-2013
JN1FAAZE0Uxxxxxxx

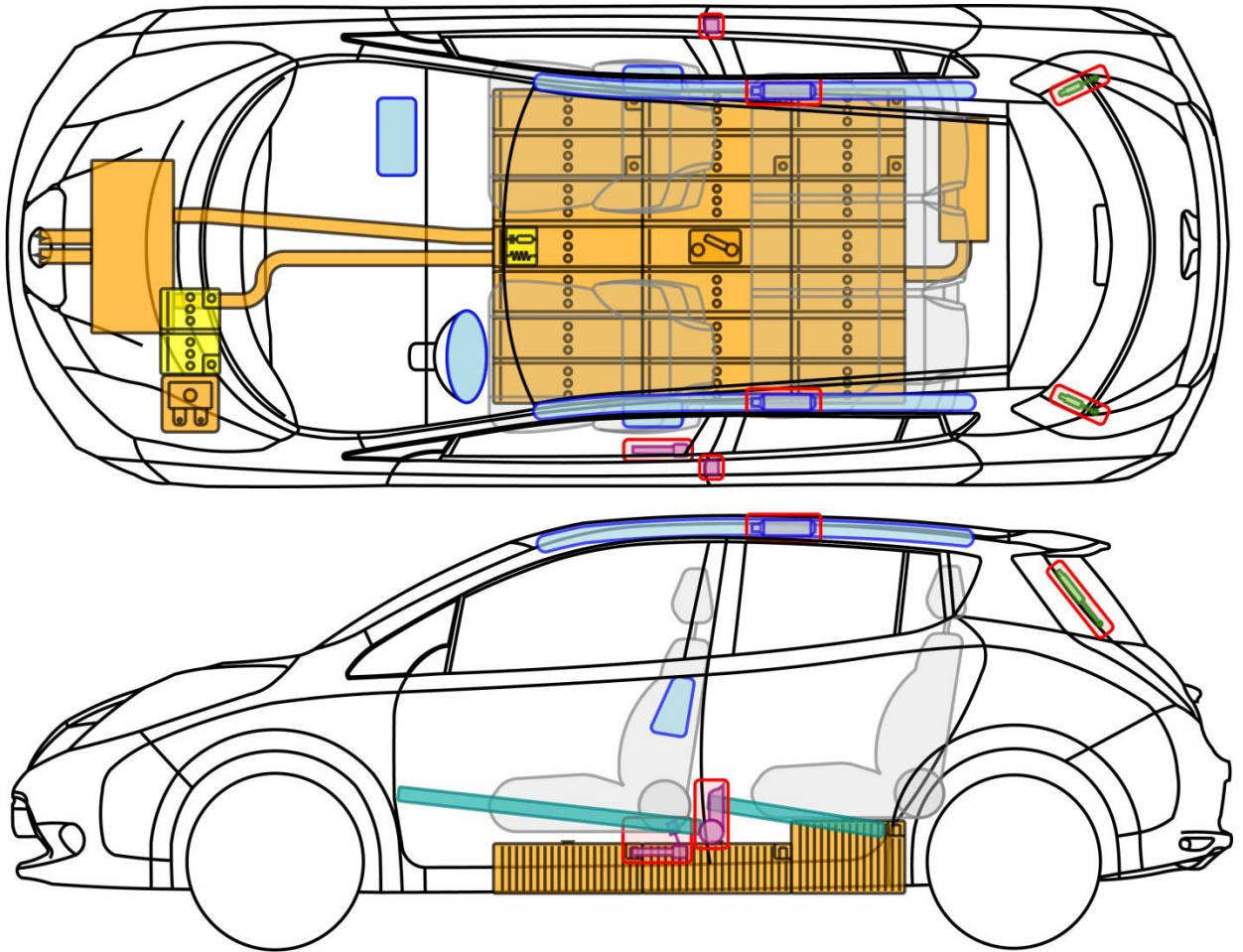

Legende

| | | | | | | | |
|--|-----------------|--|------------------------|--|-------------------|--|------------------------------|
| | Airbag | | Karosserie-verstärkung | | Steuergerät | | Hochvolt-leitung/-komponente |
| | Gas-generator | | Überroll-schutz | | 12 V Batterie | | HV-Trennstelle |
| | Gurt-straffer | | Gasdruck-dämpfer | | Hochvolt-batterie | | Sicherungs-kasten |
| | Kraftstoff-tank | | | | | | |

LEAF



LEAF

Typ: ZE0, 2011-2013
JN1FAAZE0Uxxxxxxx



Allgemeine Hinweise

- Bei Unfällen mit Airbag und/oder Gurtstrafferauslösung wird der Fahrzeugantrieb automatisch deaktiviert. Die Rückhaltesysteme sind weiterhin aktiv.
- Die Zeit bis zur vollständigen Deaktivierung des Antriebs beträgt **10 Minuten** nach Durchführung der Deaktivierungsschritte.
- **Vor Beginn von Arbeiten am Fahrzeug Ladestecker ziehen!**
- **Schutzausrüstung erforderlich (Isolierende Handschuhe bis 1000 V, Gesichtsschutz).**

Fahrzeug gegen wegrollen sichern

- Räder unterkeilen.
- Bremse betätigen
- Schalter der elektrische Parkbremse nach oben ziehen.



Deaktivieren von Hochvolt- (HV) und Rückhaltesystem (SRS)

Methode 1

1. Prüfen ob das Hochvoltsystem eingeschaltet ist. Symbol: 
2. Ist das System aktiv, Start-Stopp Knopf einmal betätigen.
3. 12 Volt Batterie abklemmen. Massekabel zuerst.





LEAF

Typ: ZE0, 2011-2013
JN1FAAZE0Uxxxxxxx



Deaktivieren von Hochvolt- (HV) und Rückhaltesystem (SRS)

Methode 2

1. Sicherungskasten lokalisieren und öffnen.



2. Dargestellte Sicherungen im Kastendeckel entfernen.

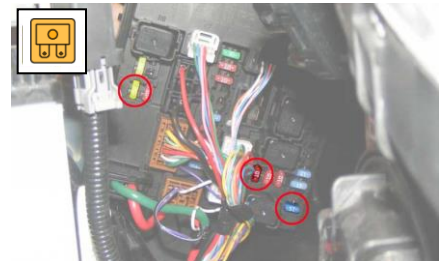

3. 12 Volt Batterie abklemmen. Massekabel zuerst.





LEAF

Typ: ZE0, 2011-2013

JN1FAAZE0Uxxxxxxx



Deaktivierung des Hochvoltsystem (HV)

Methode 3

1. HV-Trennstelle lokalisieren.
2. Abdeckung öffnen, z.B. durch abschrauben (Schlüsselweite 10 mm) oder aufhebeln.
3. Servicestecker wie dargestellt entfernen!

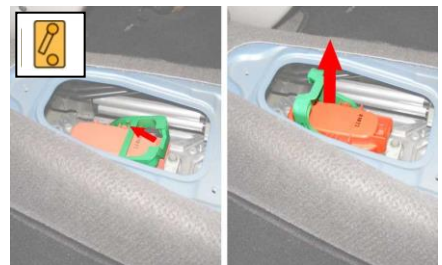
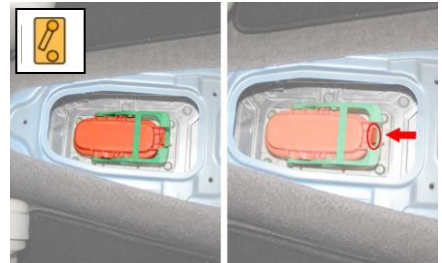

- **Kann die 12 Volt Batterie nicht abgeklemmt werden, sind die Rückhaltesysteme weiterhin aktiv!**



LEAF

Typ: ZE0, 2013-2017
SJNFAAZE0Uxxxxxxx

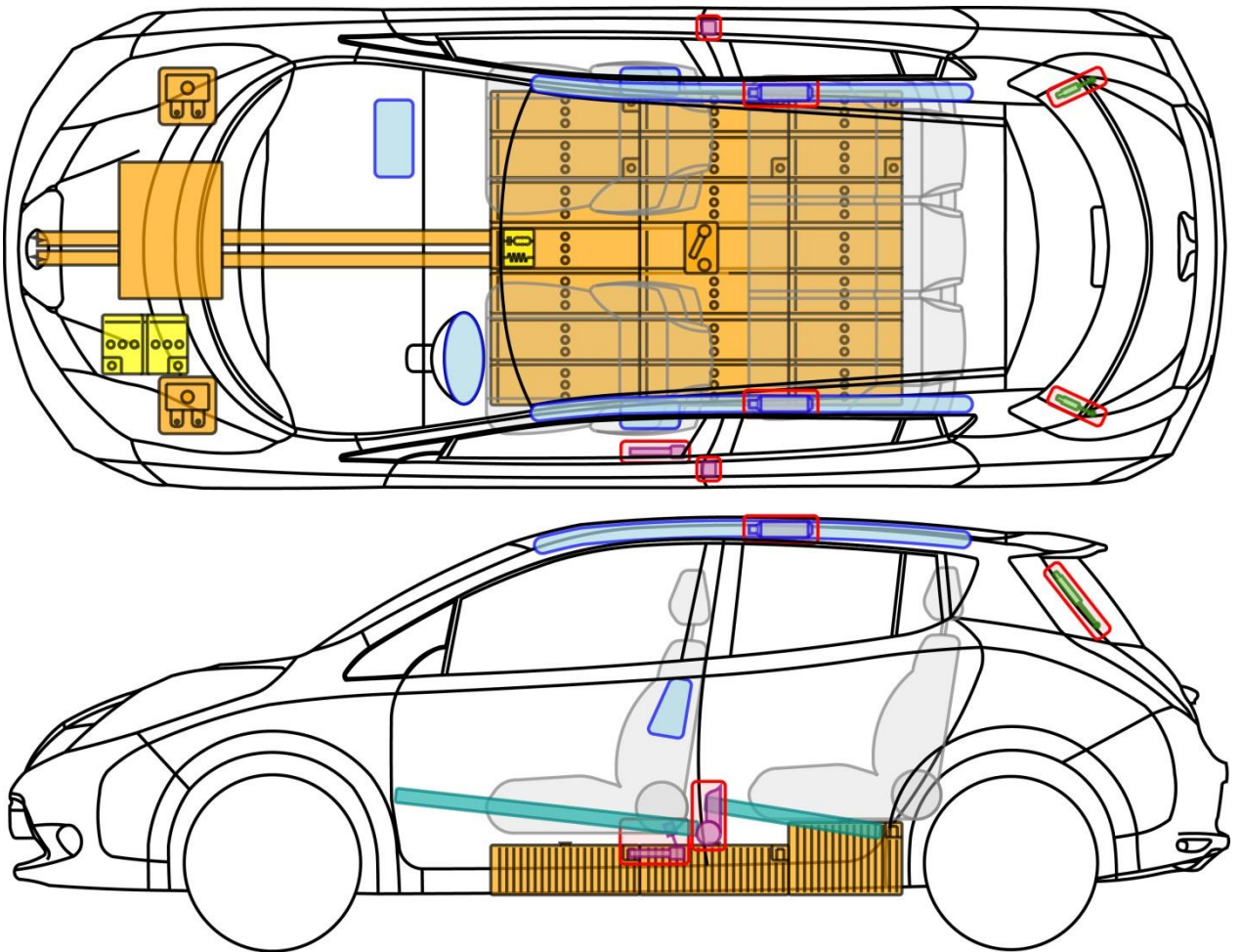

Legende

| | | | | | | | |
|--|-----------------|--|------------------------|--|-------------------|--|------------------------------|
| | Airbag | | Karosserie-verstärkung | | Steuergerät | | Hochvolt-leitung/-komponente |
| | Gas-generator | | Überroll-schutz | | 12 V Batterie | | HV-Trennstelle |
| | Gurt-straffer | | Gasdruck-dämpfer | | Hochvolt-batterie | | Sicherungs-kasten |
| | Kraftstoff-tank | | | | | | |





LEAF

Typ: ZE0, 2013-2017
SJNFAAZE0Uxxxxxxx



Allgemeine Hinweise

- Bei Unfällen mit Airbag und/oder Gurtstrafferauslösung wird der Fahrzeugantrieb automatisch deaktiviert. Die Rückhaltesysteme sind weiterhin aktiv.
- Die Zeit bis zur vollständigen Deaktivierung des Antriebs beträgt **10 Minuten** nach Durchführung der Deaktivierungsschritte.
- **Vor Beginn von Arbeiten am Fahrzeug Ladestecker ziehen!**
- **Schutzausrüstung erforderlich (Isolierende Handschuhe bis 1000 V, Gesichtsschutz).**

Fahrzeug gegen wegrollen sichern

- Räder unterkeilen.
- Fußfeststellbremse betätigen.

Deaktivieren von Hochvolt- (HV) und Rückhaltesystem (SRS)

Methode 1

1. Prüfen ob das Hochvoltsystem eingeschaltet ist. Symbol: 
2. Ist das System aktiv, Start-Stopp Knopf einmal betätigen.
3. 12 Volt Batterie abklemmen. Massekabel zuerst.





LEAF

Typ: ZE0, 2013-2017
SJNFAAZE0Uxxxxxxx



Deaktivieren von Hochvolt- (HV) und Rückhaltesystem (SRS)

Methode 2

1. Sicherungskasten 1 lokalisieren und öffnen.



2. Dargestellte Sicherungen im Kastendeckel entfernen.



3. Sicherungskasten 2 lokalisieren und öffnen.



4. Dargestellte Sicherung im Kastendeckel entfernen.



5. 12 Volt Batterie abklemmen. Massekabel zuerst.





LEAF

Typ: ZE0, 2013-2017
SJNFAAZE0Uxxxxxxx



Deaktivierung des Hochvoltsystem (HV)

Methode 3

1. HV-Trennstelle lokalisieren.
2. Abdeckung öffnen, z.B. durch abschrauben (Schlüsselweite 10 mm) oder aufhebeln.
3. Servicestecker wie dargestellt entfernen!



- **Kann die 12 Volt Batterie nicht abgeklemmt werden, sind die Rückhaltesysteme weiterhin aktiv!**



LEAF

Typ: ZE1, 2017-
SJNFAAZE1U0xxxxxx

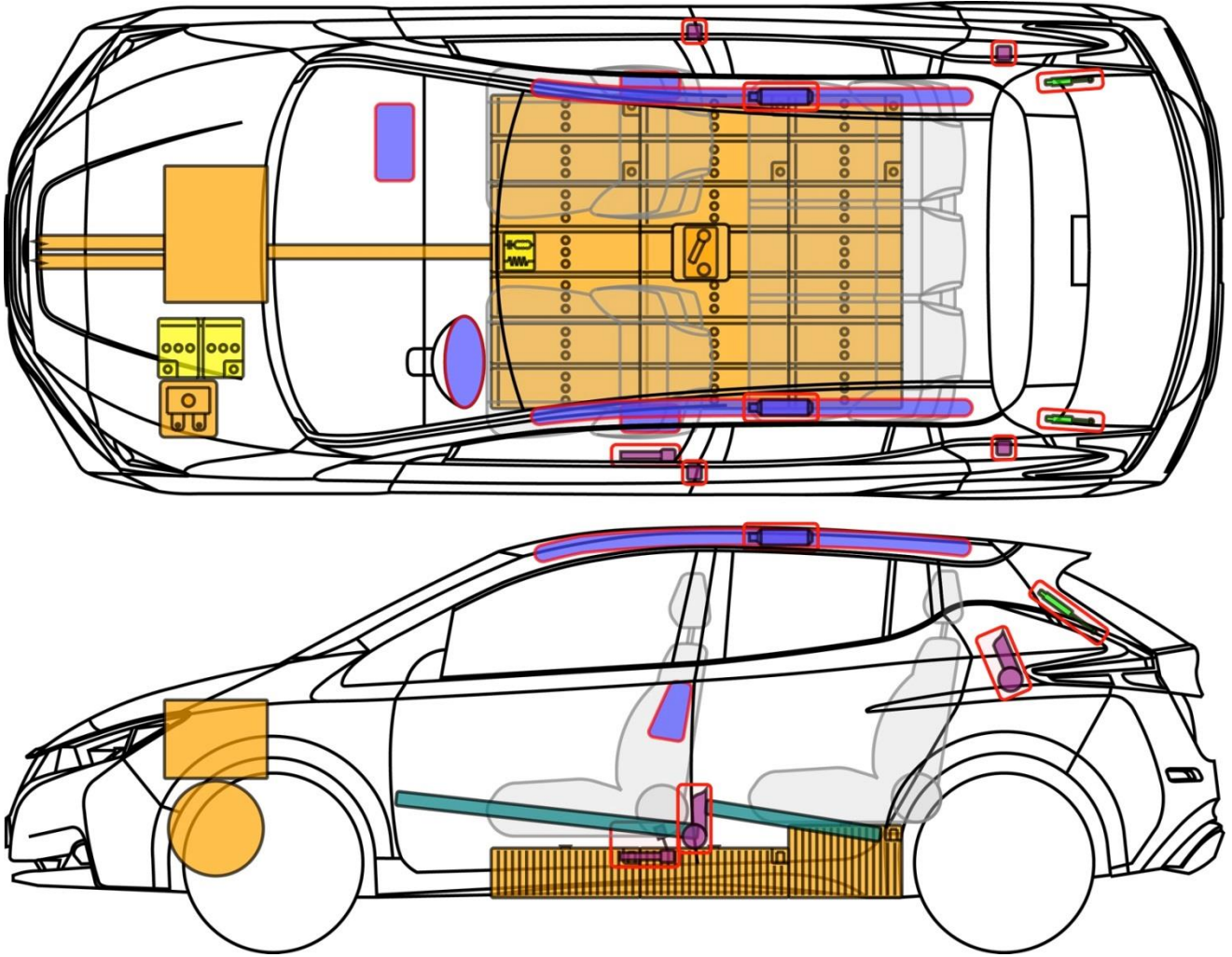

Legende

| | | | | | | | |
|--|-----------------|--|-------------------------|--|-------------------|--|------------------------------|
| | Airbag | | Karosserie-verstärkung | | Steuergerät | | Hochvolt-leitung/-komponente |
| | Gas-generator | | Überroll-schutz | | 12 V Batterie | | HV-Trennstelle |
| | Gurt-straffer | | Gasdruck-dämpfer | | Hochvolt-batterie | | Sicherungs-kasten |
| | Kraftstoff-tank | | Fußgänger-Schutz-system | | | | |





LEAF

Typ: ZE1, 2017-
SJNFAAZE1U0xxxxxx



Allgemeine Hinweise

- Bei Unfällen mit Airbag und/oder Gurtstrafferauslösung wird der Fahrzeugantrieb automatisch deaktiviert. Die Rückhaltesysteme sind weiterhin aktiv.
- Die Zeit bis zur vollständigen Deaktivierung der Rückhaltesysteme beträgt **10 Minuten** nach Durchführung der Deaktivierungsschritte.
- **Schutzausrüstung erforderlich (Isolierende Handschuhe bis 1000 V, Gesichtsschutz).**

Fahrzeug gegen wegrollen sichern

- Räder unterkeilen.
- Fußfeststellbremse betätigen.

Deaktivieren von Hochvolt- (HV) und Rückhaltesystem (SRS)

Methode 1

1. Prüfen ob das Hochvoltsystem eingeschaltet ist. Symbol: 
 2. Ist das System aktiv, Start-Stopp Knopf einmal betätigen.
 3. 12 Volt Batterie abklemmen. Massekabel zuerst.
- **Achtung: Die Rückhaltesysteme sind erst nach ca. 10 min. vollständig deaktiviert!**





LEAF

Typ: ZE1, 2017-

SJNFAAZE1U0xxxxxx



Deaktivieren von Hochvolt- (HV) und Rückhaltesystem (SRS)

Methode 2

1. Sicherungskasten 1 lokalisieren und öffnen.



2. Dargestellte Sicherung im Kastendeckel entfernen.



3. 12 Volt Batterie abklemmen. Massekabel zuerst.



- **Achtung: Die Rückhaltesysteme sind erst nach ca. 10 min. vollständig deaktiviert!**



LEAF

Typ: ZE1, 2017-

SJNFAAZE1U0xxxxxx



Deaktivieren von Hochvolt- (HV) und Rückhaltesystem (SRS)

Methode 3

1. HV-Trennstelle lokalisieren.
2. Abdeckung unten vor der Rückbank im hinteren Bereich anheben (ist geklammert) und entfernen. Befestigungsschrauben des darunter liegenden Deckels ausdrehen (Schlüsselweite 10 mm) und Deckel abnehmen.
3. Servicestecker wie dargestellt entfernen!
4. 12 Volt Batterie abklemmen. Massekabel zuerst.

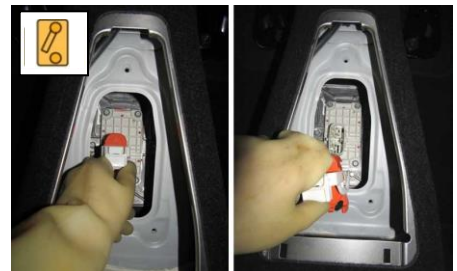
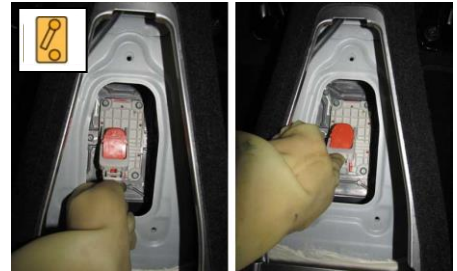

- **Kann die 12 Volt Batterie nicht abgeklemmt werden, sind die Rückhaltesysteme weiterhin aktiv!**
- **Achtung: Die Rückhaltesysteme sind erst nach ca. 10 min. vollständig deaktiviert!**







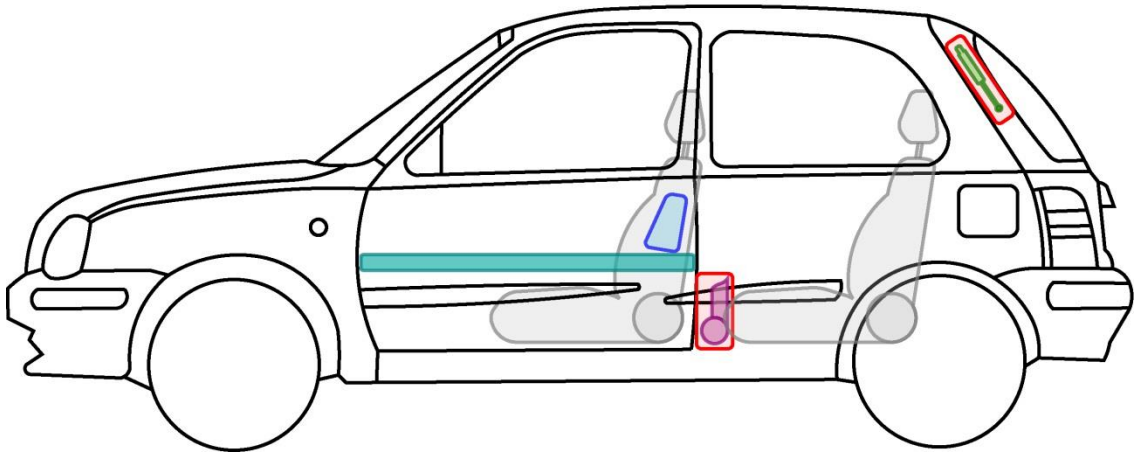
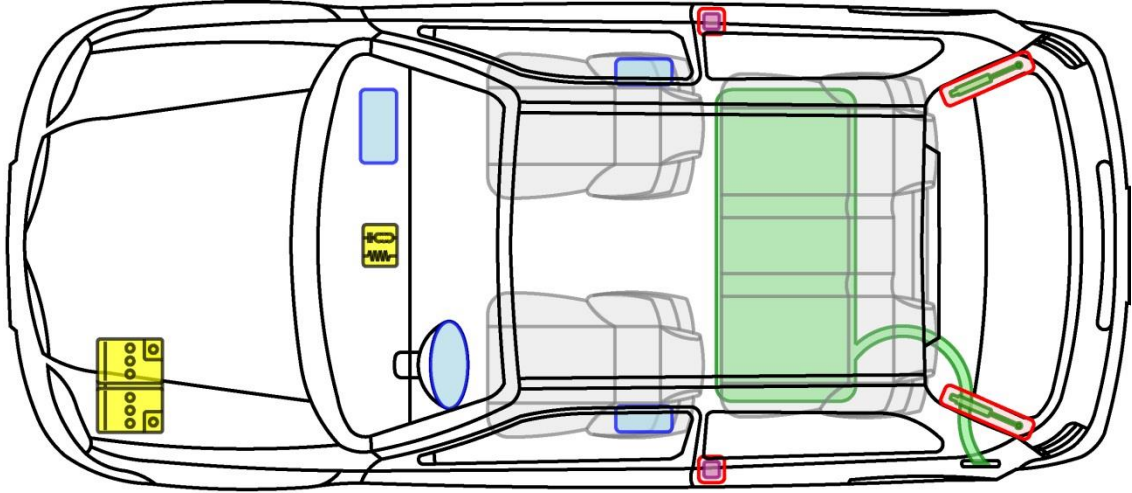

MICRA 3-Türer

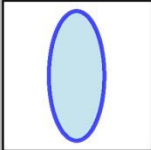
Typ: K11, 1996-2003

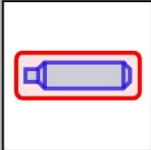

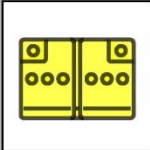
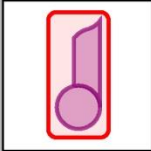
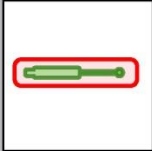
Legende

| | | | | | |
|---|-------------------|---|----------------------------|--|---------------------|
|  | Airbag |  | Karosserie- verstärkung |  | Steuergerät |
|  | Gas- generator |  | Überroll- schutz |  | Batterie |
|  | Gurt- straffer |  | Gasdruck- dämpfer |  | Kraftstoff- tank |

MICRA



MICRA 5-Türer

Typ: K11, 1996-2003

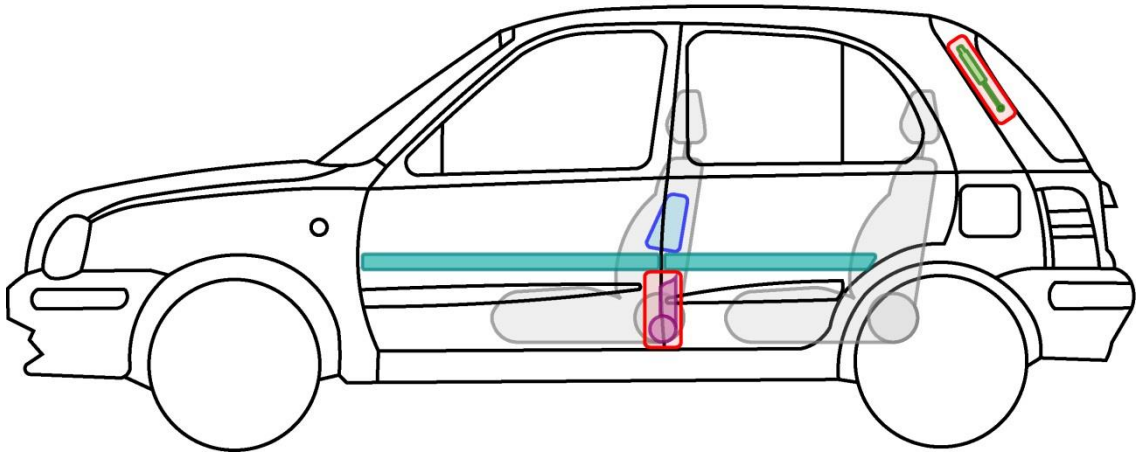
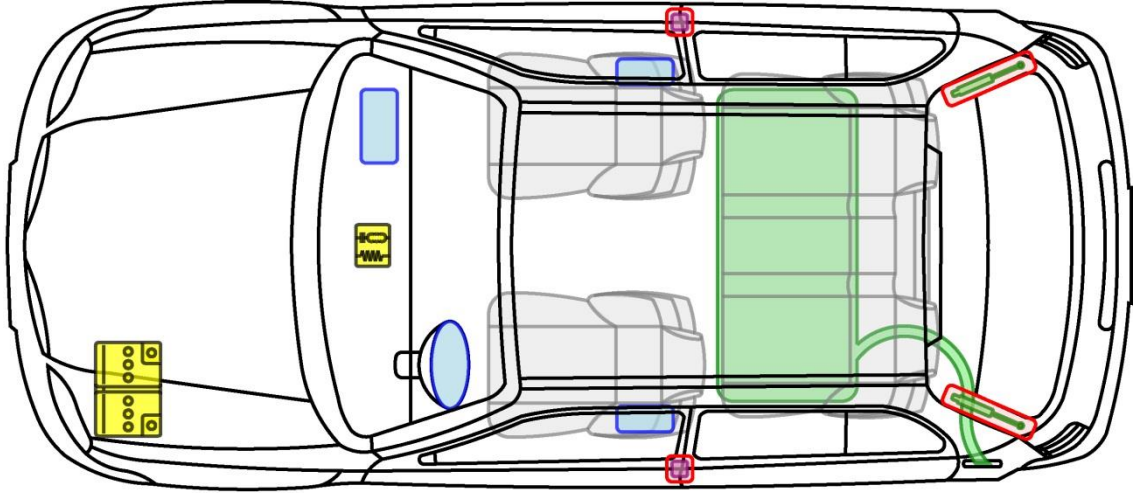

Legende

| | | | | | |
|--|---------------|--|------------------------|--|-----------------|
| | Airbag | | Karosserie-verstärkung | | Steuergerät |
| | Gas-generator | | Überroll-schutz | | Batterie |
| | Gurt-straffer | | Gasdruck-dämpfer | | Kraftstoff-tank |

MICRA



MICRA 3-Türer

Typ: K12, 2003-2010

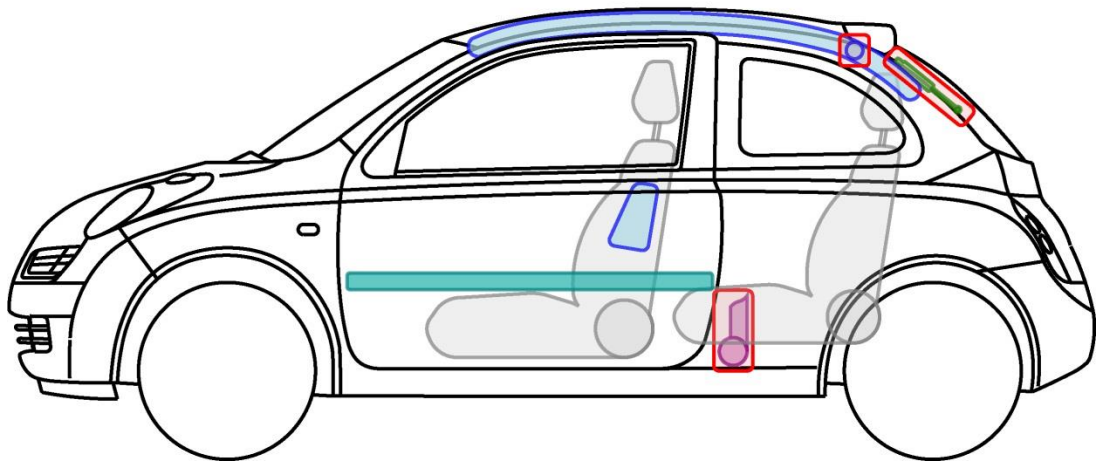
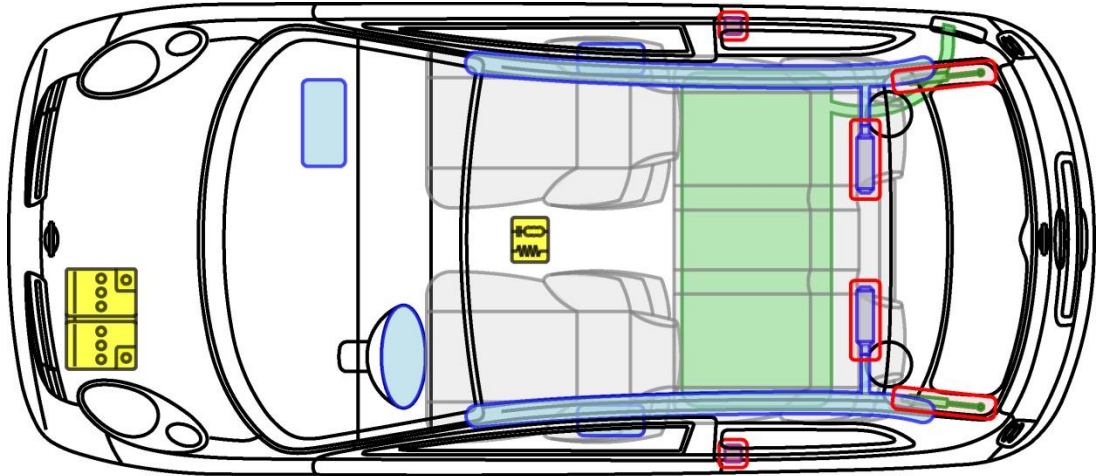

Legende

| | | | | | |
|--|-------------------|--|----------------------------|--|---------------------|
| | Airbag | | Karosserie- verstärkung | | Steuergerät |
| | Gas- generator | | Überroll- schutz | | Batterie |
| | Gurt- straffer | | Gasdruck- dämpfer | | Kraftstoff- tank |

MICRA







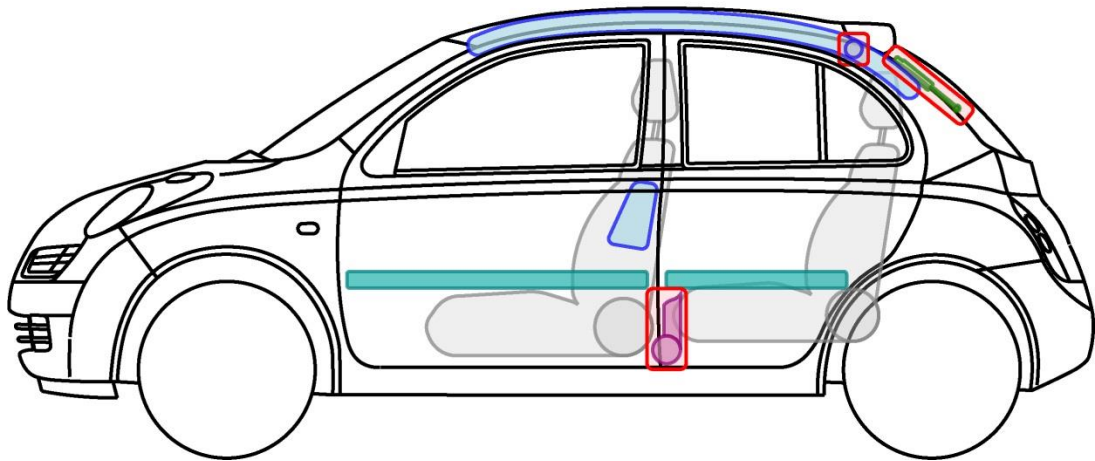
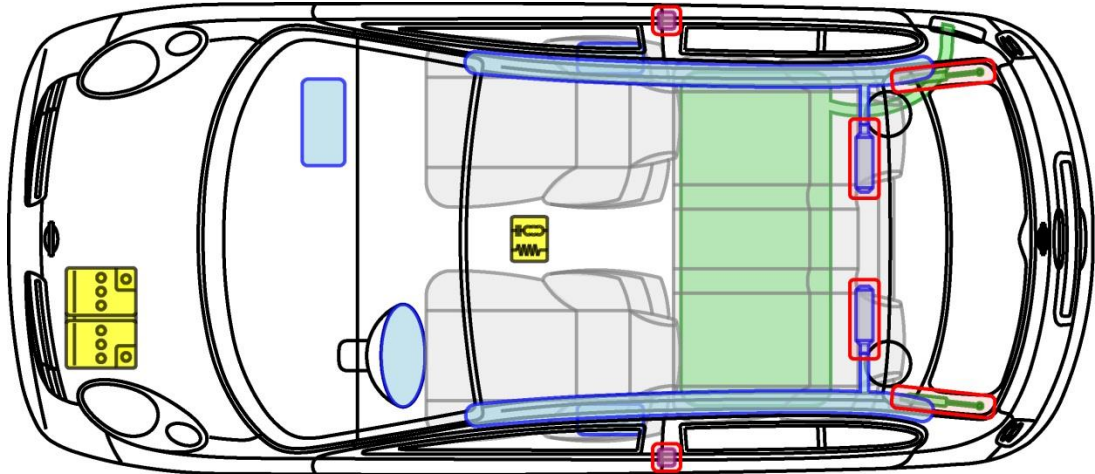

MICRA 5-Türer

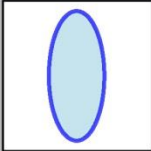
Typ: K12, 2003-2010

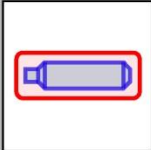

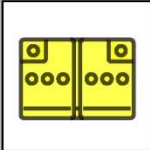
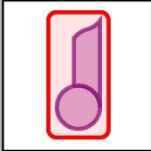
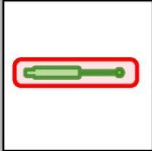
Legende

| | | | | | |
|---|-------------------|---|----------------------------|--|---------------------|
|  | Airbag |  | Karosserie- verstärkung |  | Steuergerät |
|  | Gas- generator |  | Überroll- schutz |  | Batterie |
|  | Gurt- straffer |  | Gasdruck- dämpfer |  | Kraftstoff- tank |





MICRA C+C

Typ: K12, 2005-2009

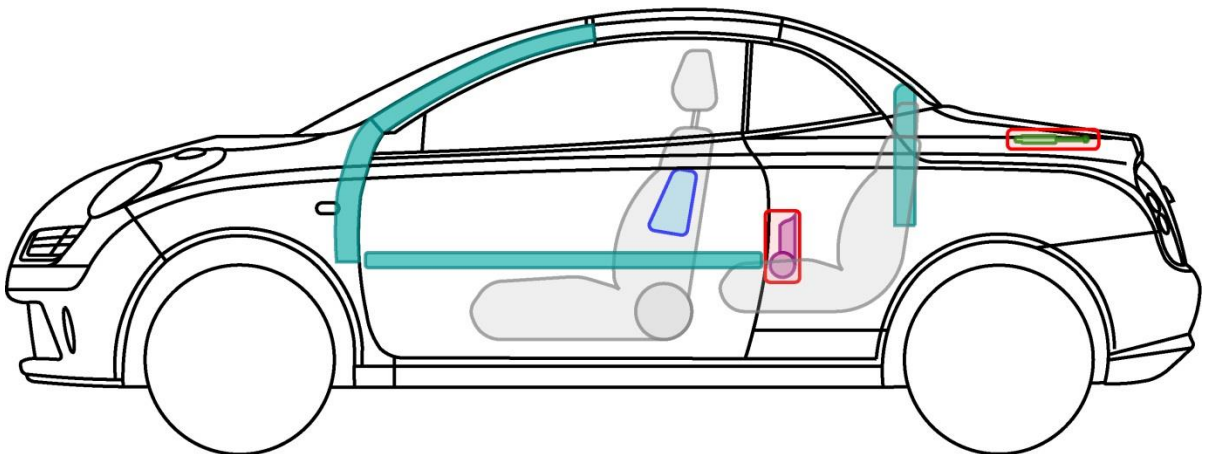
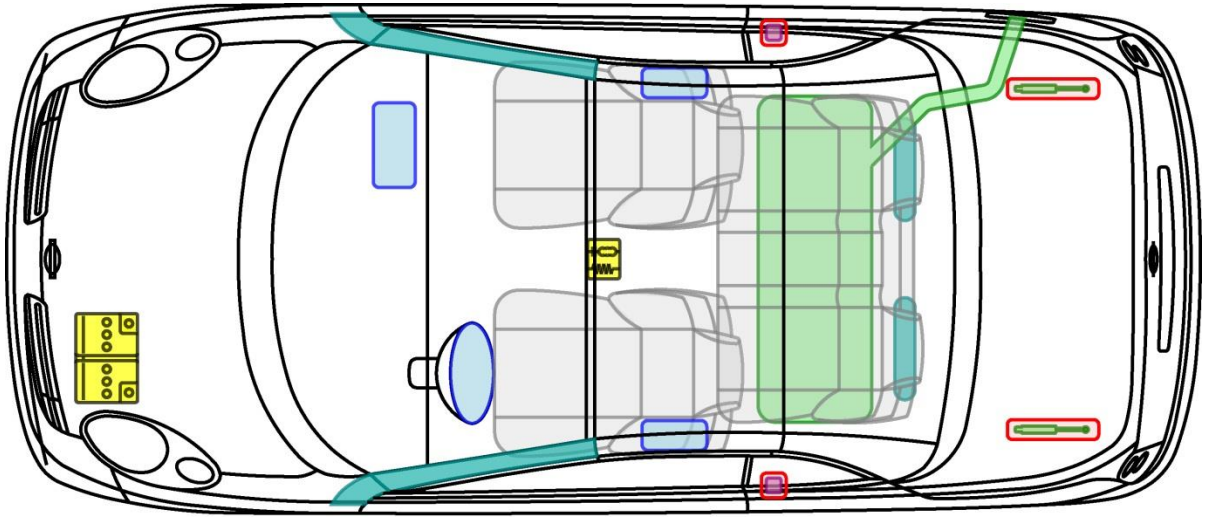

Legende

| | | | | | |
|--|-------------------|--|----------------------------|--|---------------------|
| | Airbag | | Karosserie- verstärkung | | Steuergerät |
| | Gas- generator | | Überroll- schutz | | Batterie |
| | Gurt- straffer | | Gasdruck- dämpfer | | Kraftstoff- tank |

MICRA



MICRA 5-Türer

Typ: K13, 2010-2017

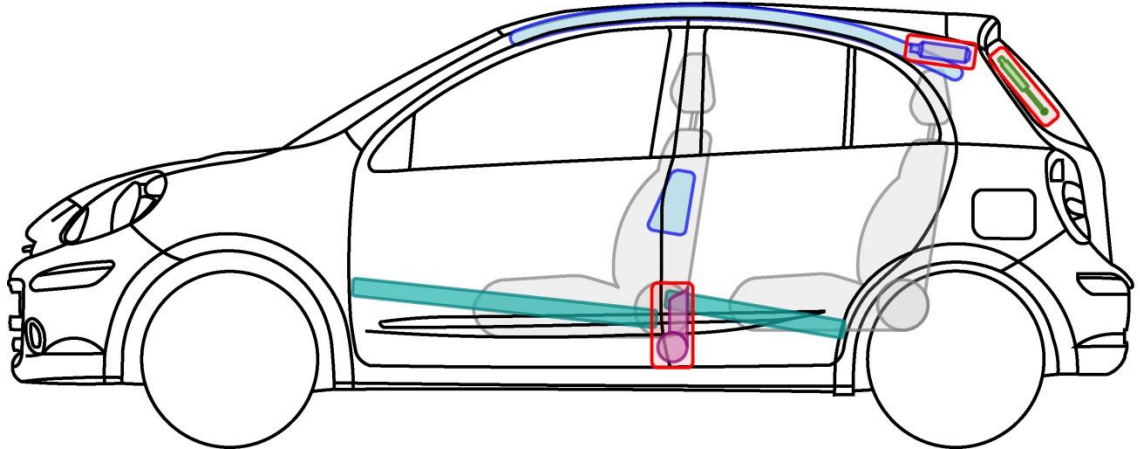
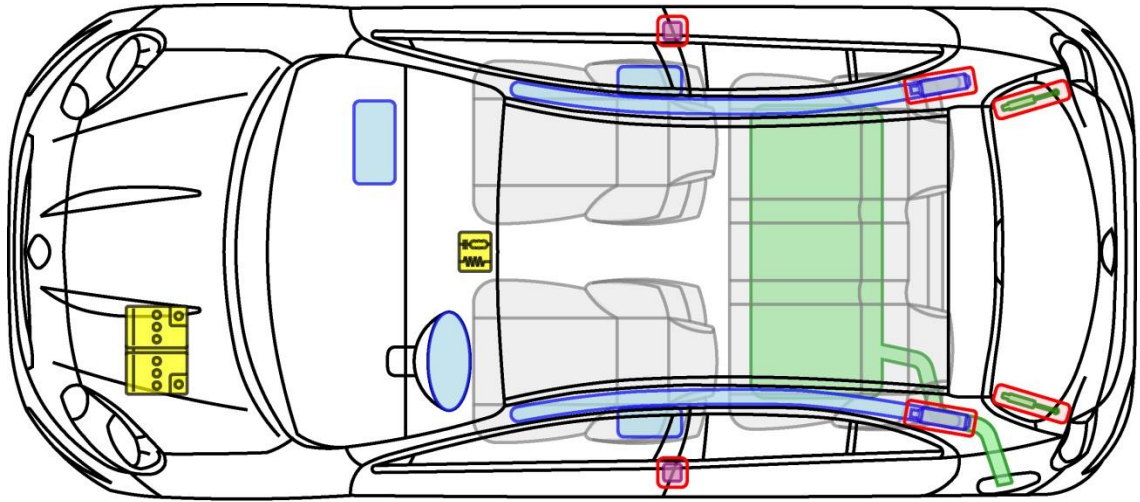

Legende

| | | | | | |
|--|---------------|--|------------------------|--|-----------------|
| | Airbag | | Karosserie-verstärkung | | Steuergerät |
| | Gas-generator | | Überroll-schutz | | Batterie |
| | Gurt-straffer | | Gasdruck-dämpfer | | Kraftstoff-tank |

MICRA



MICRA

Typ: K14, 2017-

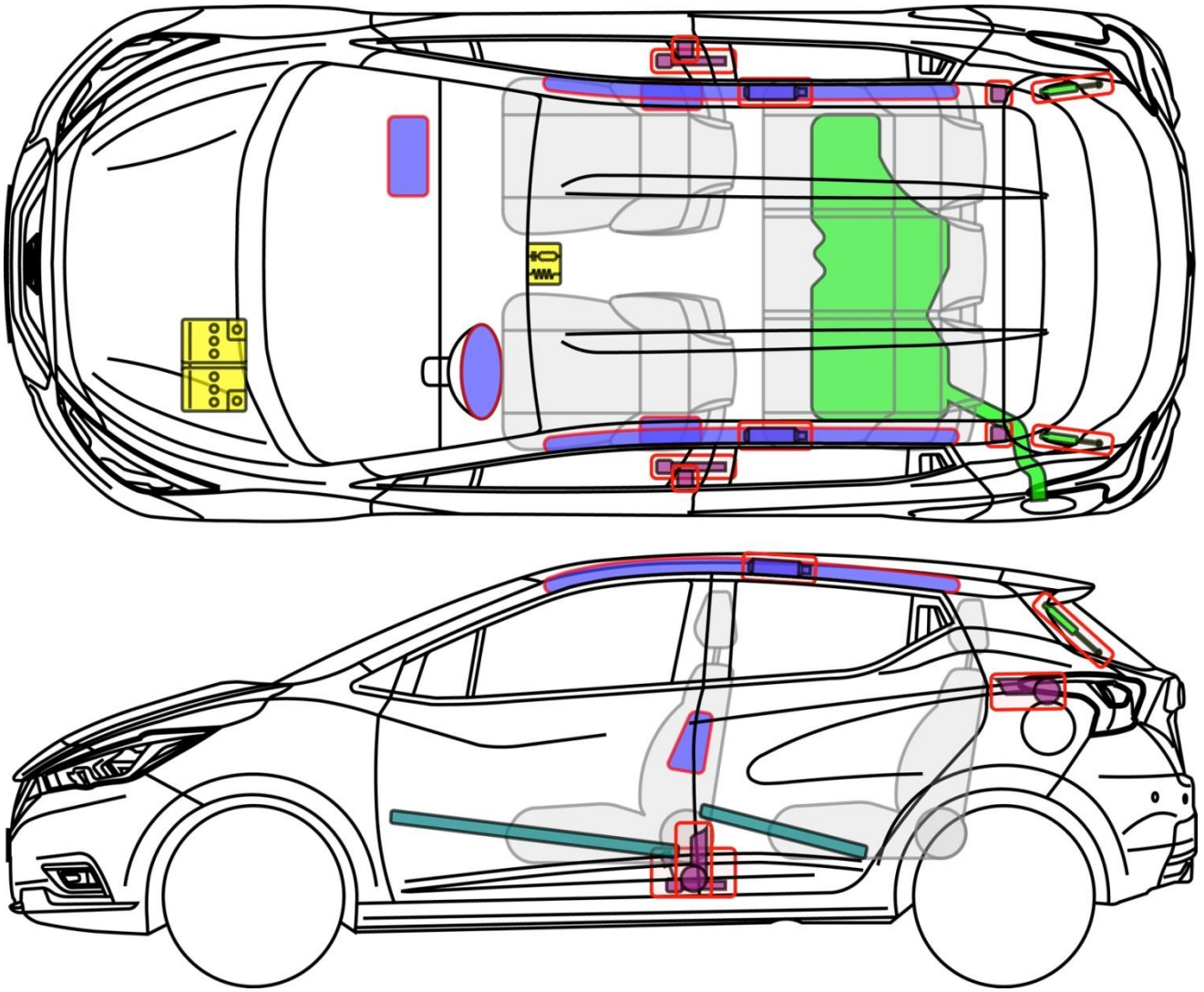

Legende

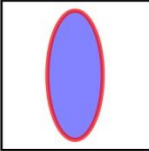
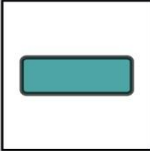
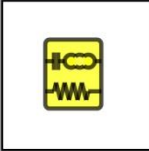
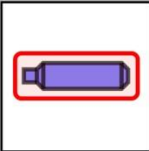
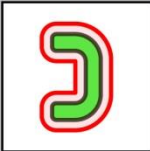
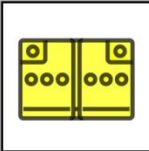
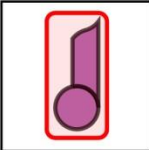
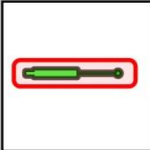
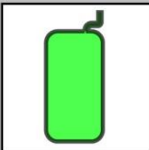
| | | | | | |
|---|-------------------|---|----------------------------|--|---------------------|
|  | Airbag |  | Karosserie- verstärkung |  | Steuergerät |
|  | Gas- generator |  | Überroll- schutz |  | Batterie |
|  | Gurt- straffer |  | Gasdruck- dämpfer |  | Kraftstoff- tank |









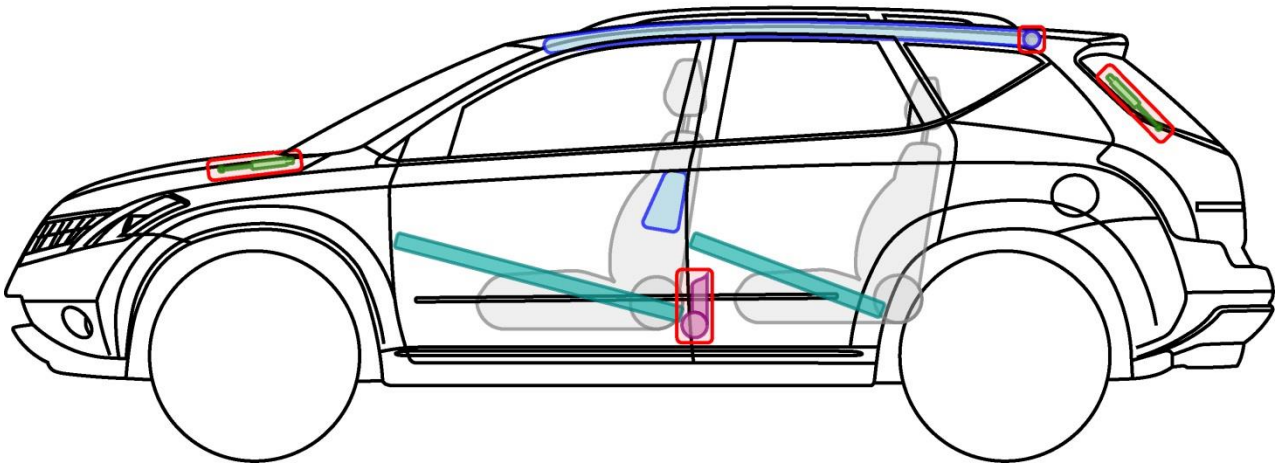
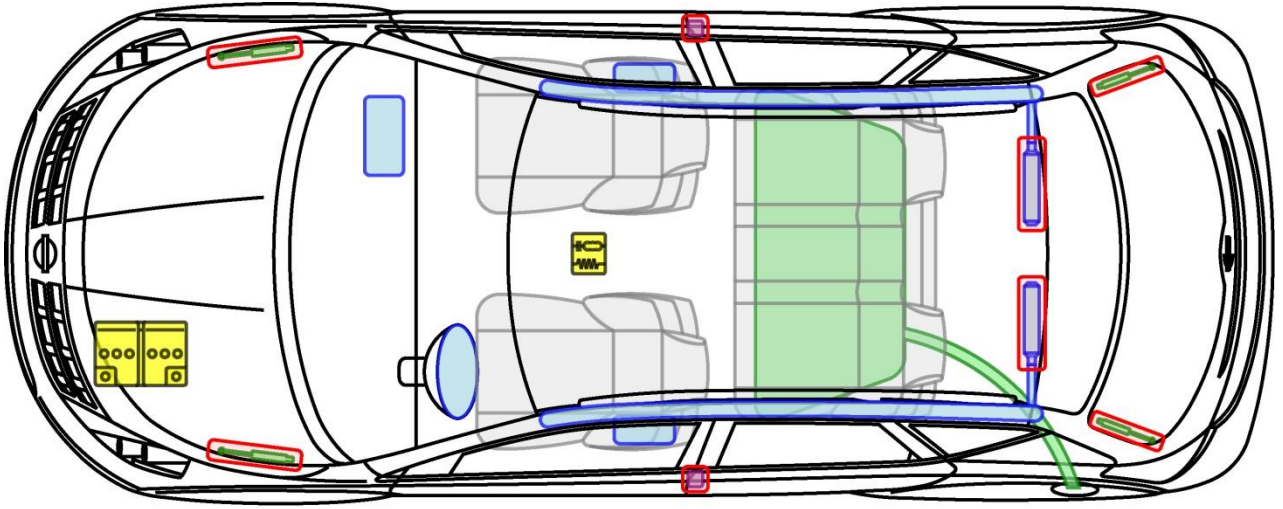

MURANO

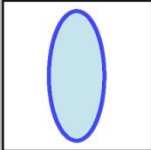
Typ: Z50, 2005-2008

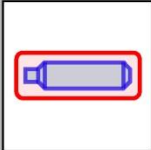

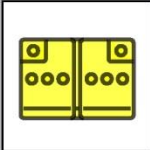
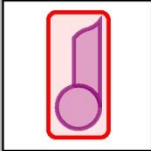
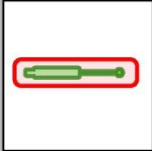
Legende

| | | | | | |
|---|-------------------|---|----------------------------|--|---------------------|
|  | Airbag |  | Karosserie- verstärkung |  | Steuergerät |
|  | Gas- generator |  | Überroll- schutz |  | Batterie |
|  | Gurt- straffer |  | Gasdruck- dämpfer |  | Kraftstoff- tank |

MURANO







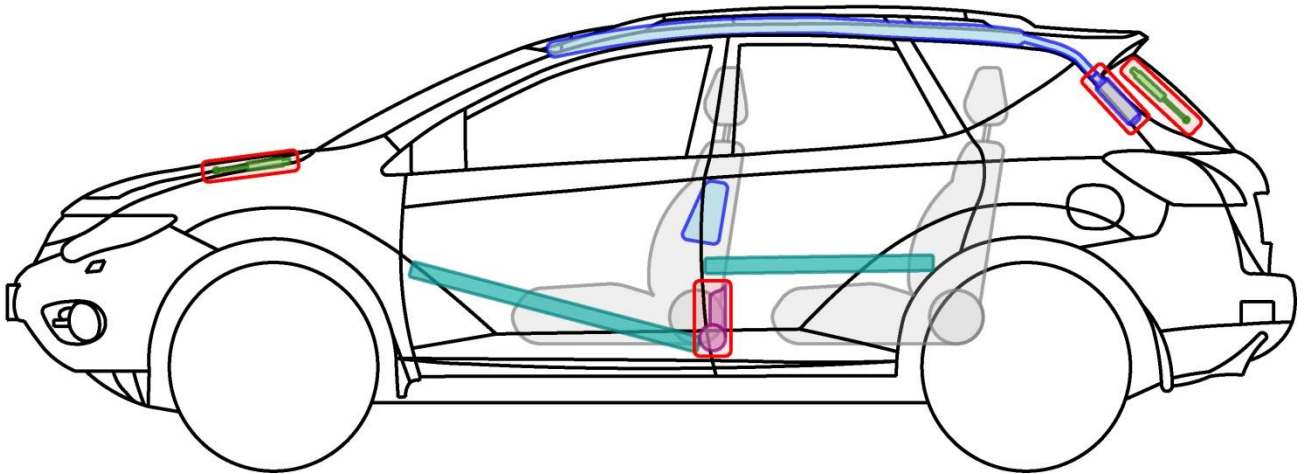
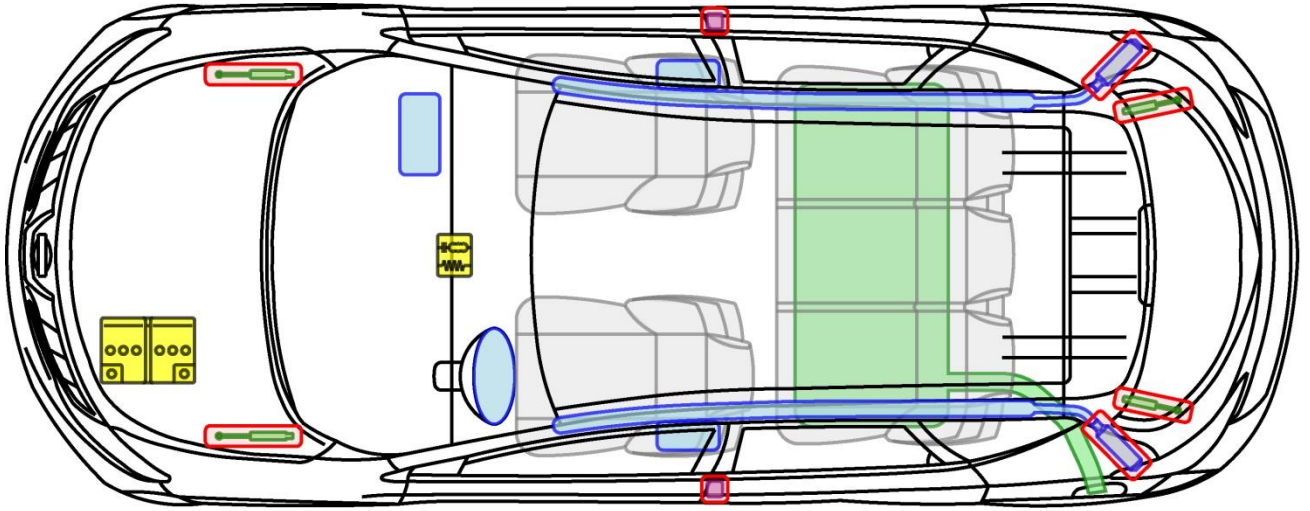

MURANO

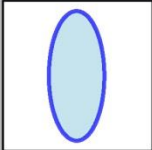
Typ: Z51, 2008-

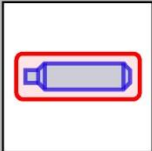

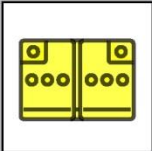
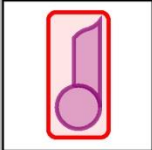
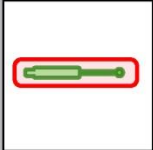
Legende

| | | | | | |
|---|-------------------|---|----------------------------|--|---------------------|
|  | Airbag |  | Karosserie- verstärkung |  | Steuergerät |
|  | Gas- generator |  | Überroll- schutz |  | Batterie |
|  | Gurt- straffer |  | Gasdruck- dämpfer |  | Kraftstoff- tank |

MURANO







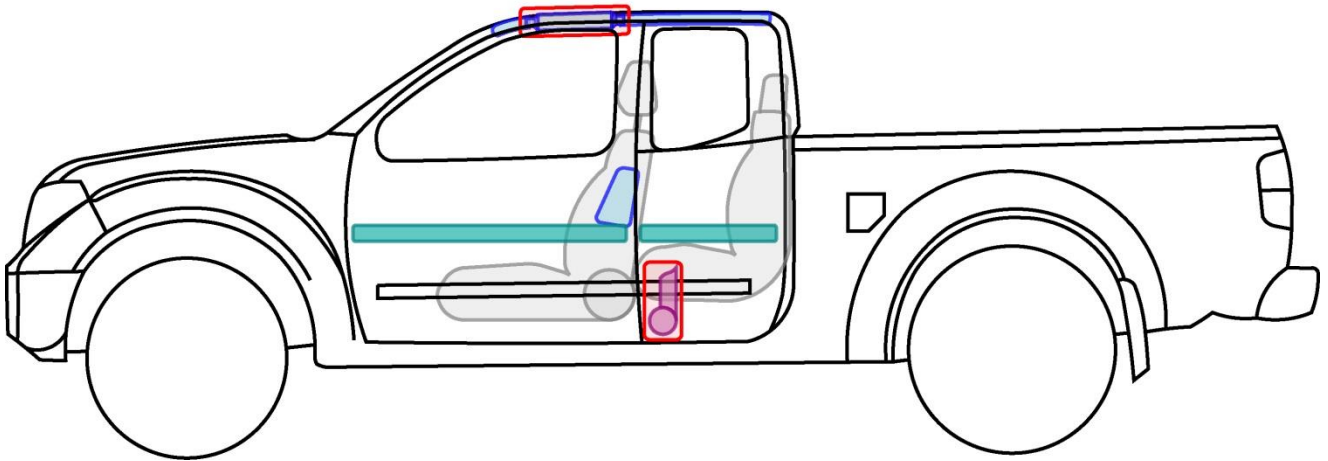
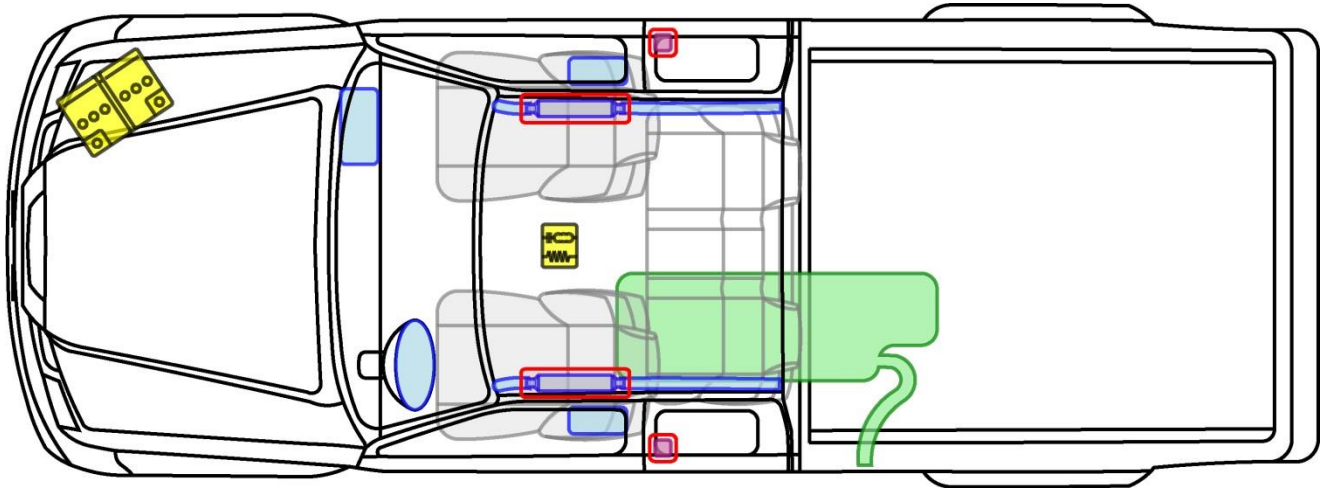

NAVARA King Cab

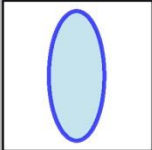
Typ: D40, 2005-2015

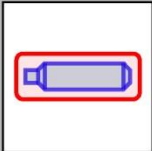

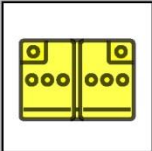
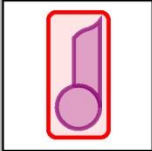
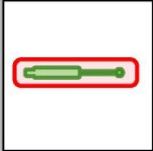
Legende

| | | | | | |
|---|-------------------|---|----------------------------|--|---------------------|
|  | Airbag |  | Karosserie- verstärkung |  | Steuergerät |
|  | Gas- generator |  | Überroll- schutz |  | Batterie |
|  | Gurt- straffer |  | Gasdruck- dämpfer |  | Kraftstoff- tank |

NAVARA







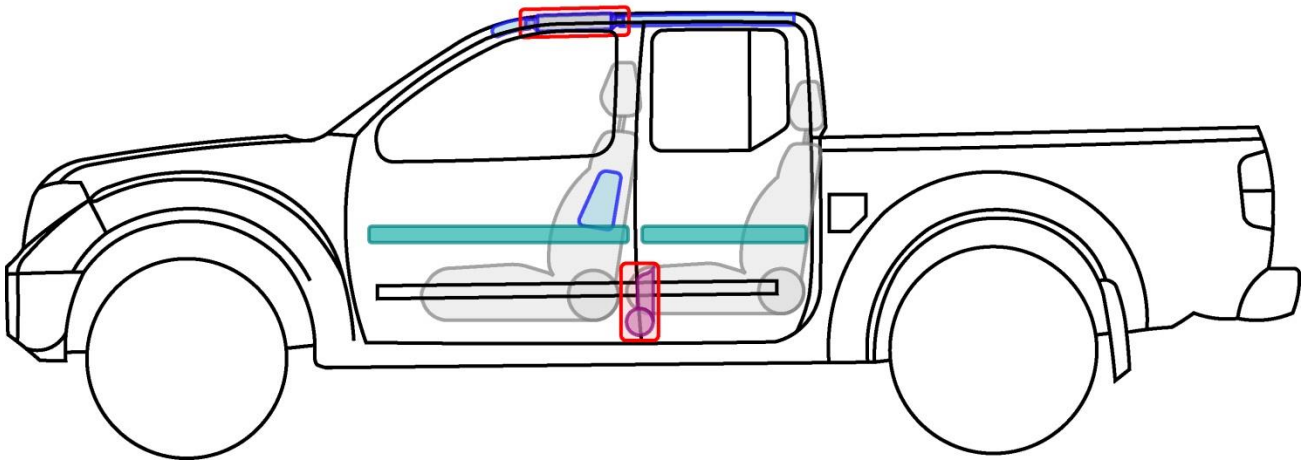
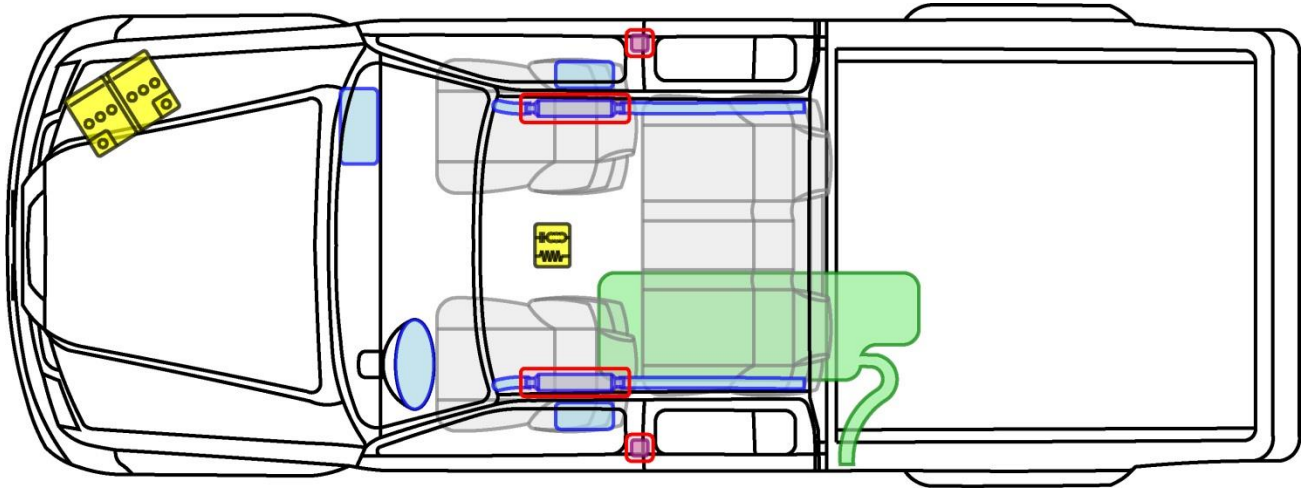

NAVARA Crew Cab

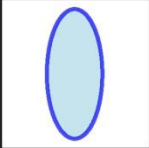
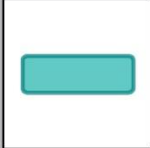
Typ: D40, 2005-2015

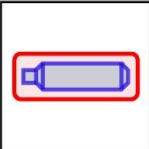

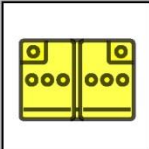
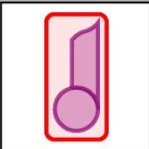
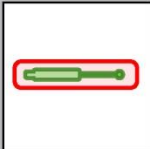
Legende

| | | | | | |
|---|-------------------|---|----------------------------|--|---------------------|
|  | Airbag |  | Karosserie- verstärkung |  | Steuergerät |
|  | Gas- generator |  | Überroll- schutz |  | Batterie |
|  | Gurt- straffer |  | Gasdruck- dämpfer |  | Kraftstoff- tank |

NAVARA



NAVARA King Cab

Typ: D23, 2015-

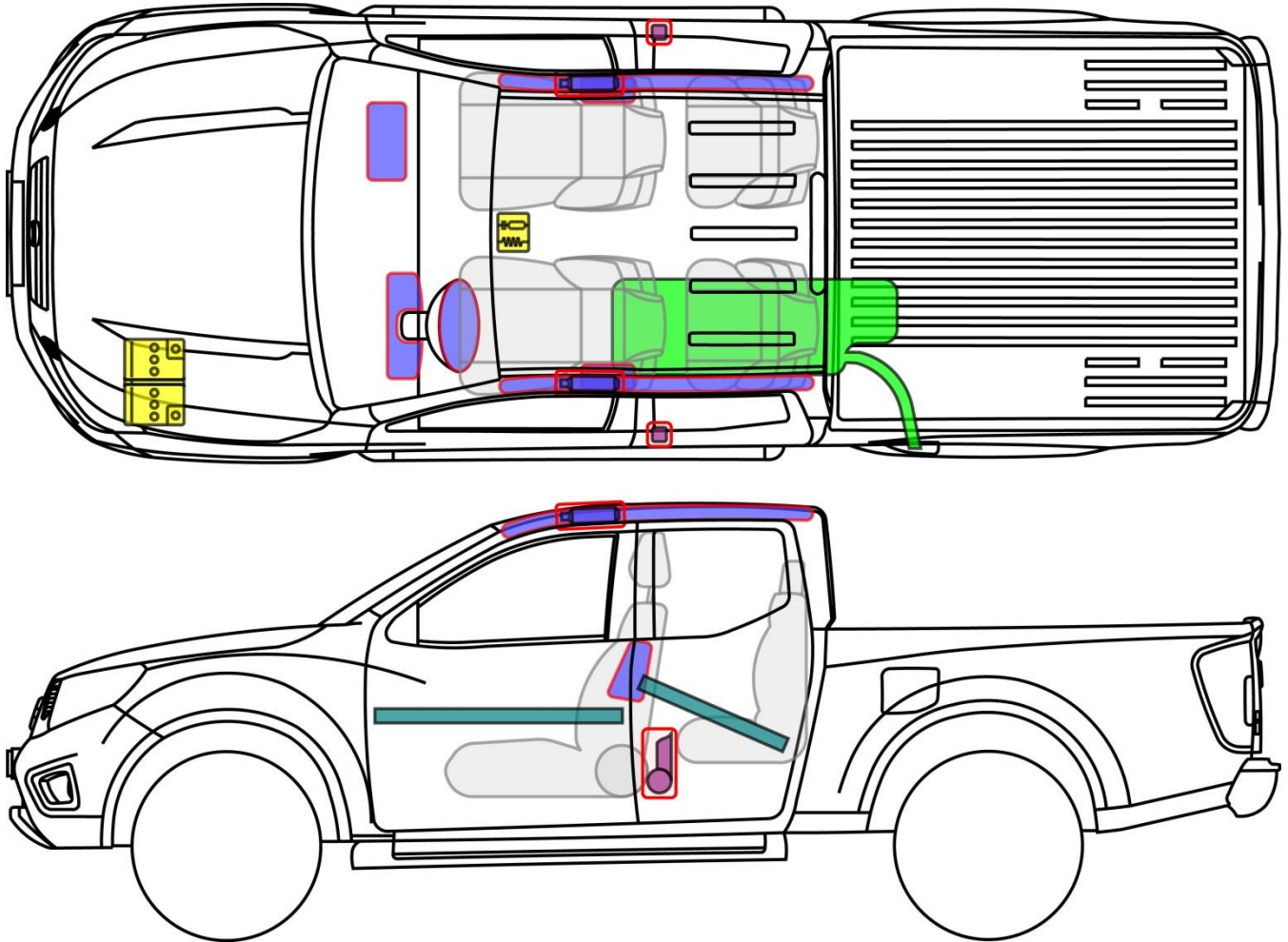

Legende

| | | | | | |
|--|-------------------|--|----------------------------|--|---------------------|
| | Airbag | | Karosserie- verstärkung | | Steuergerät |
| | Gas- generator | | Überroll- schutz | | Batterie |
| | Gurt- straffer | | Gasdruck- dämpfer | | Kraftstoff- tank |

NAVARA





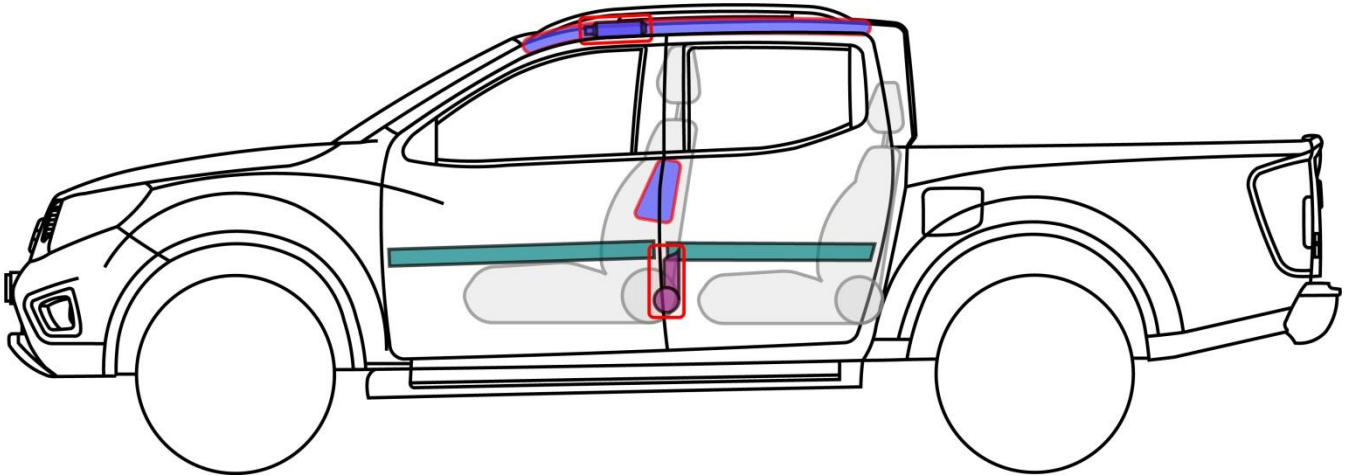
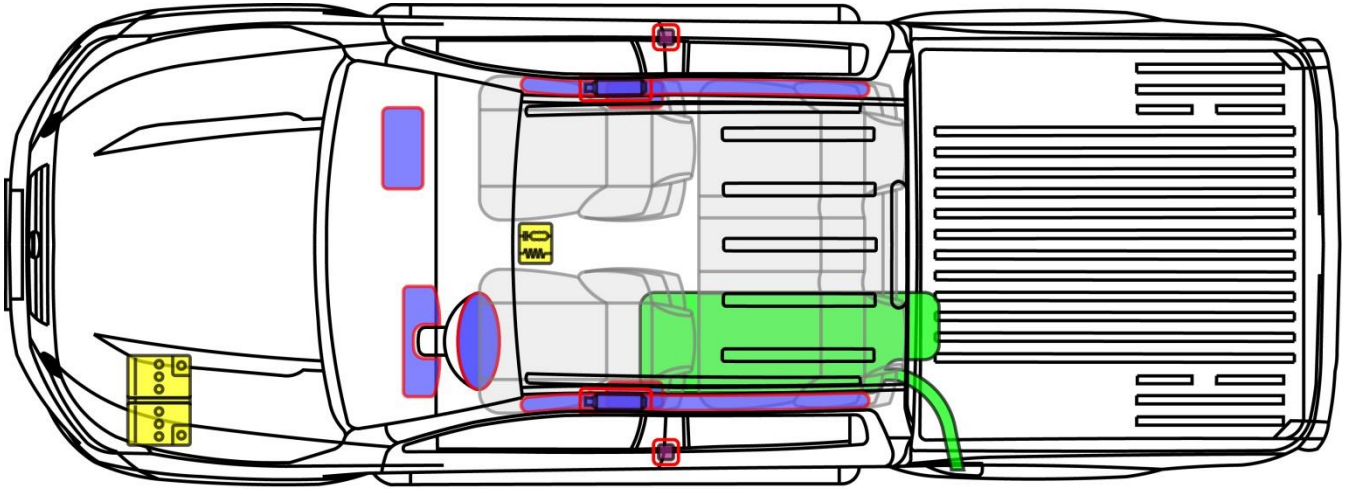

NAVARA Crew Cab

Typ: D23, 2015-

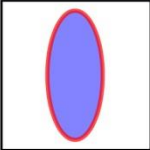

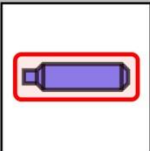
Legende

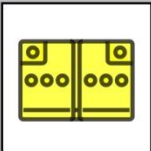
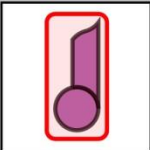
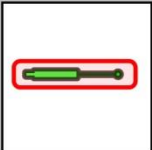
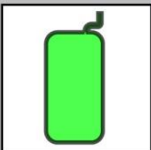
| | | | | | |
|---|-------------------|---|----------------------------|--|---------------------|
|  | Airbag |  | Karosserie- verstärkung |  | Steuergerät |
|  | Gas- generator |  | Überroll- schutz |  | Batterie |
|  | Gurt- straffer |  | Gasdruck- dämpfer |  | Kraftstoff- tank |





NOTE

Typ: E11, 2006-2013

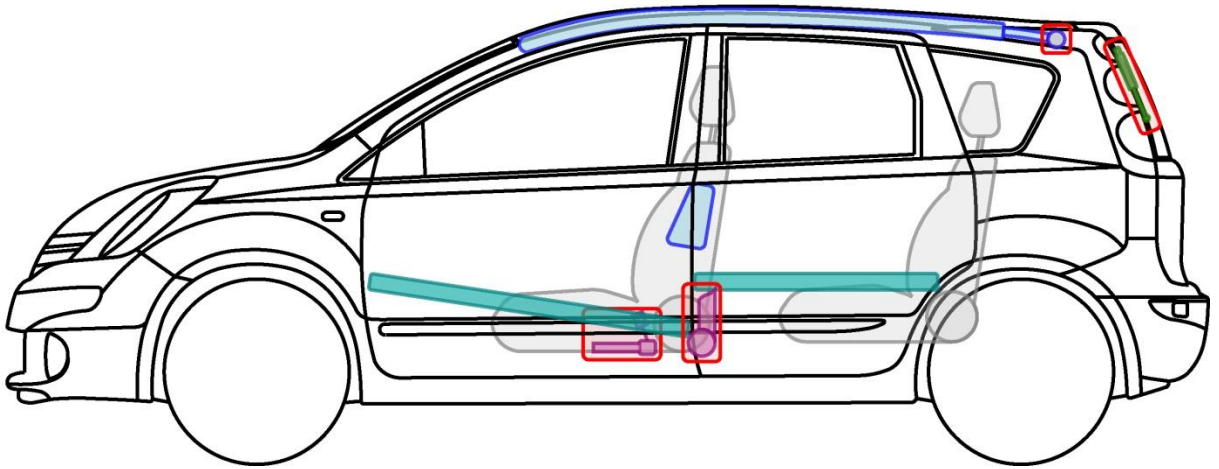
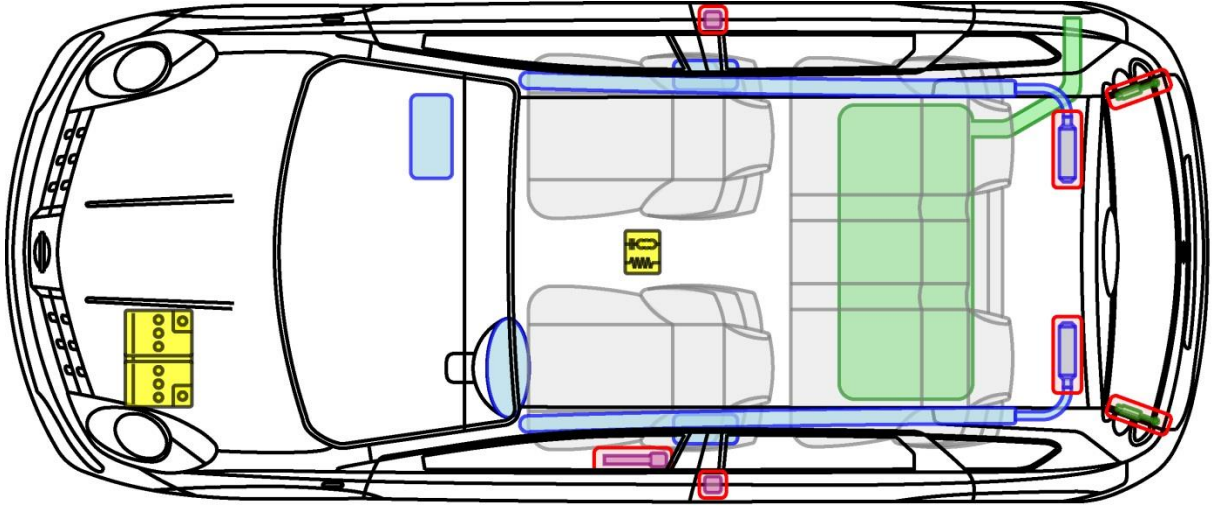

Legende

| | | | | | |
|--|-------------------|--|----------------------------|--|---------------------|
| | Airbag | | Karosserie- verstärkung | | Steuergerät |
| | Gas- generator | | Überroll- schutz | | Batterie |
| | Gurt- straffer | | Gasdruck- dämpfer | | Kraftstoff- tank |

NOTE



NOTE

Typ: E12, 2013-

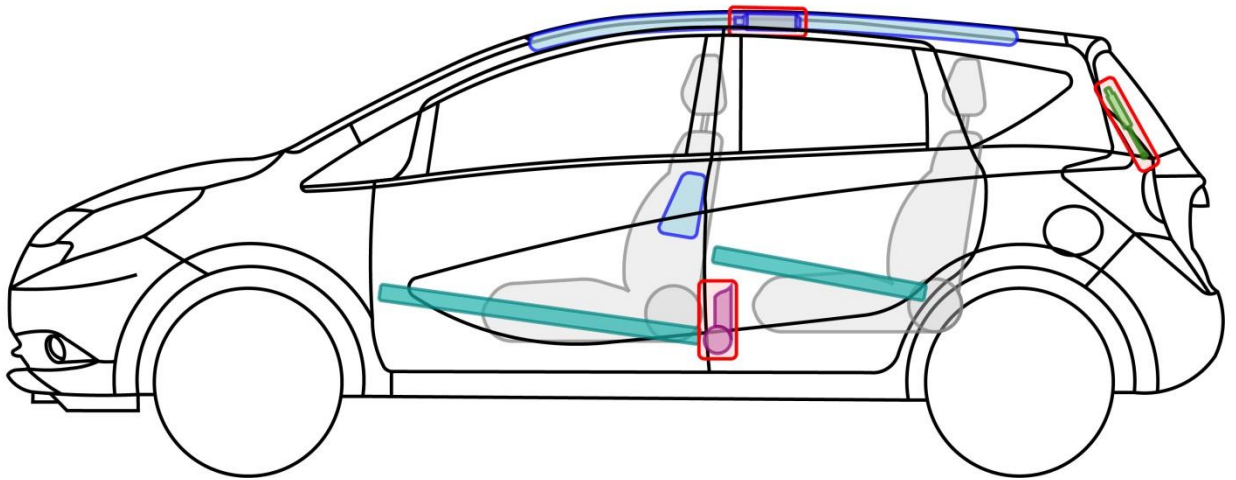
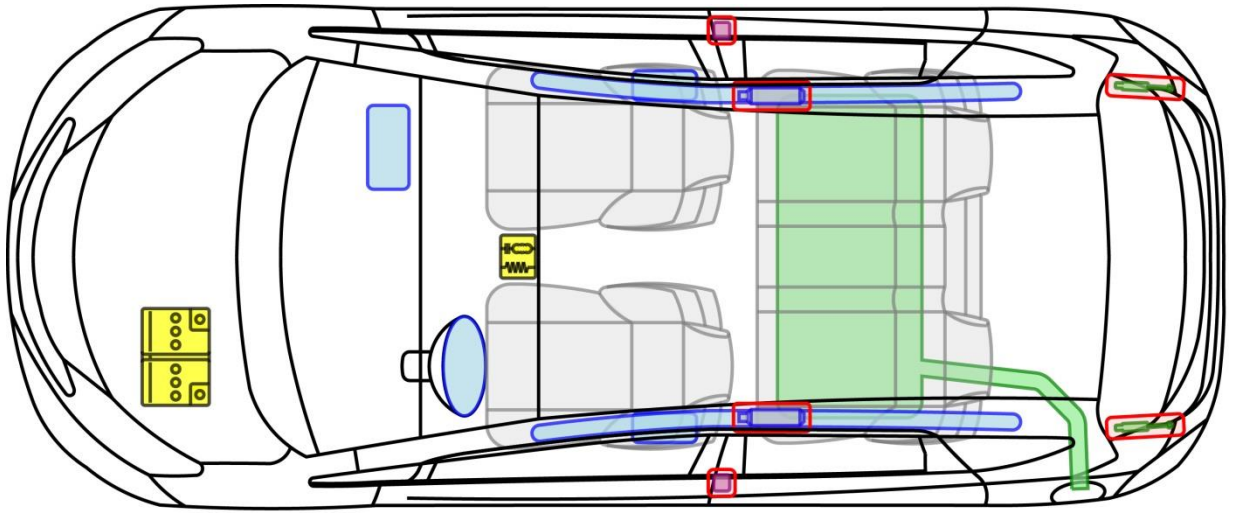

Legende

| | | | | | |
|--|-------------------|--|----------------------------|--|---------------------|
| | Airbag | | Karosserie- verstärkung | | Steuergerät |
| | Gas- generator | | Überroll- schutz | | Batterie |
| | Gurt- straffer | | Gasdruck- dämpfer | | Kraftstoff- tank |

NOTE







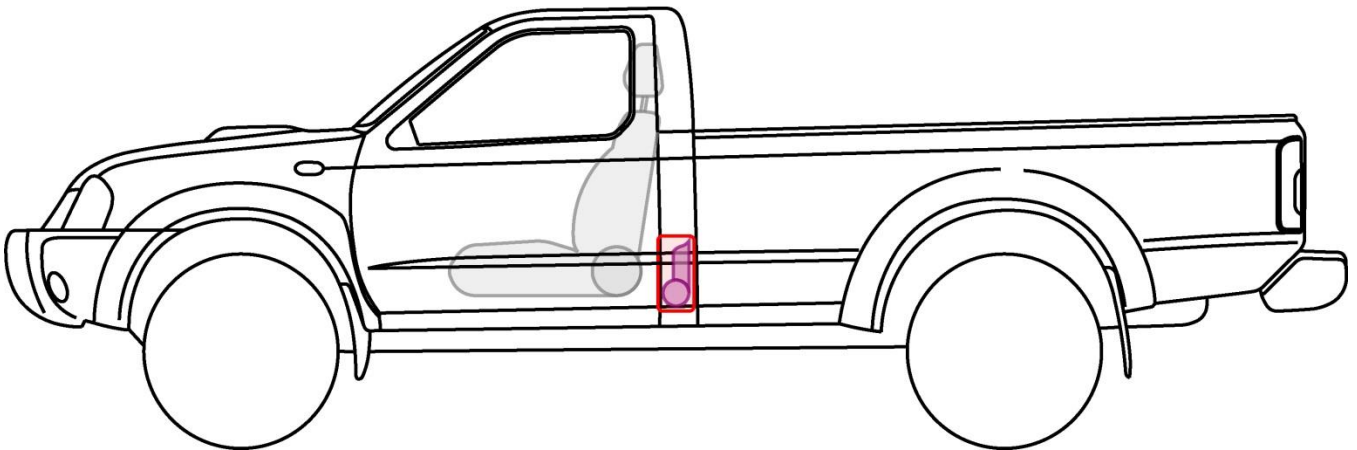
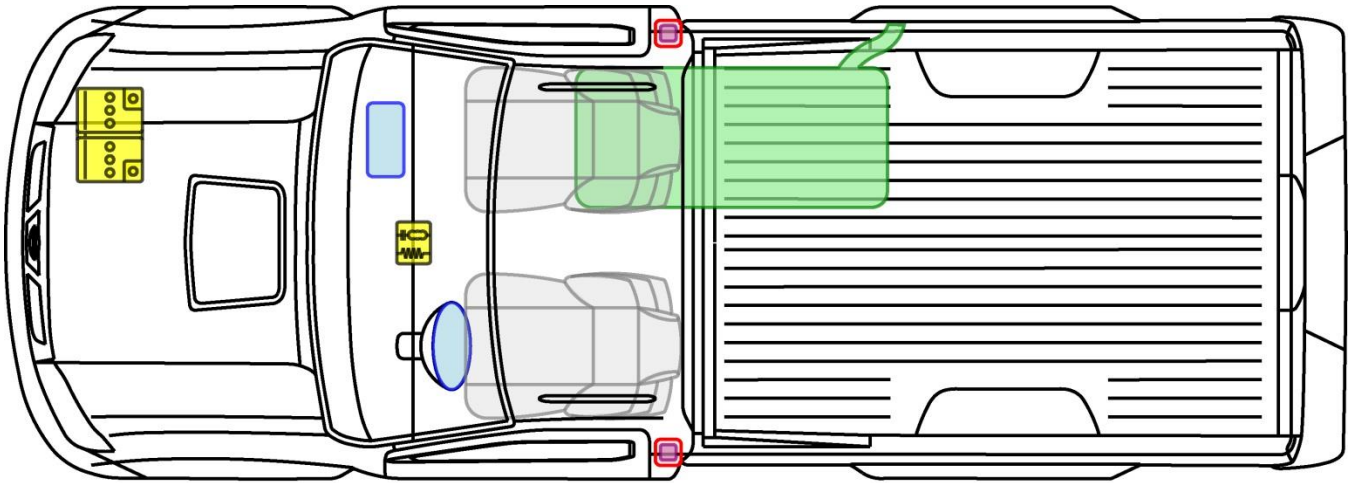

NP300 Single Cab

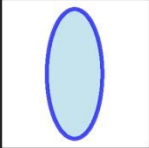
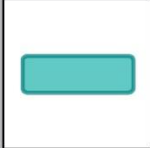
Typ: D22, 2008-2011

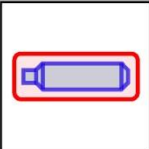

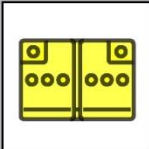
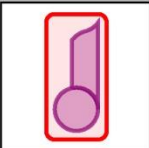
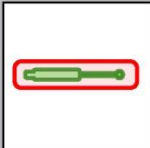
Legende

| | | | | | |
|---|-------------------|---|----------------------------|--|---------------------|
|  | Airbag |  | Karosserie- verstärkung |  | Steuergerät |
|  | Gas- generator |  | Überroll- schutz |  | Batterie |
|  | Gurt- straffer |  | Gasdruck- dämpfer |  | Kraftstoff- tank |

NP300







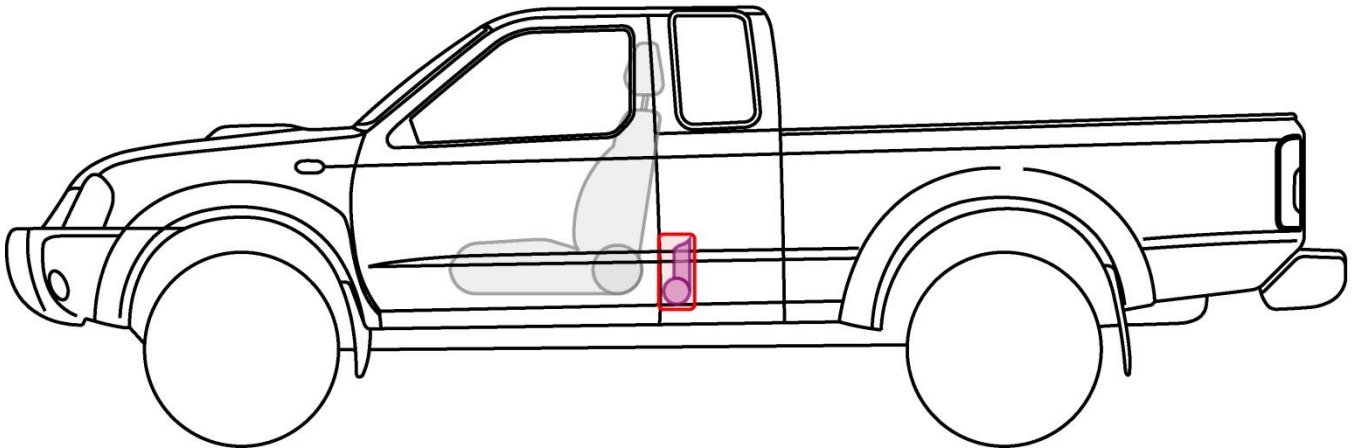
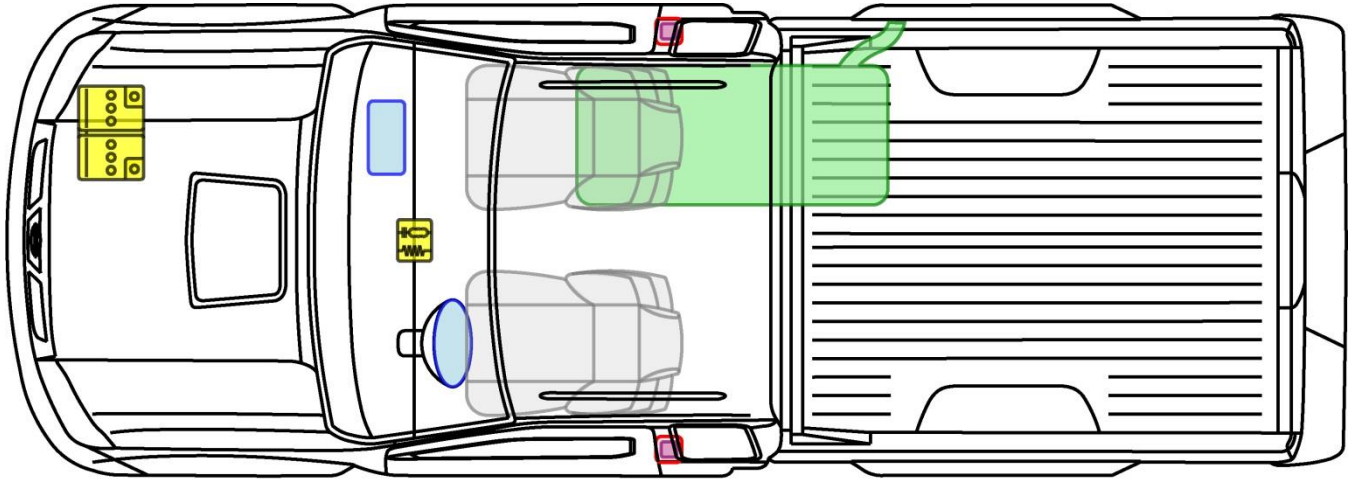

NP300 King Cab

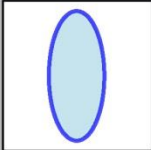
Typ: D22, 2008-2011

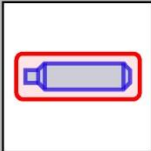

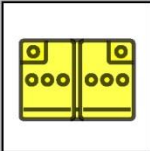
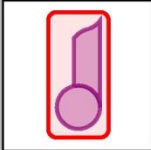
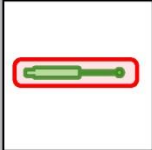
Legende

| | | | | | |
|---|-------------------|---|----------------------------|--|---------------------|
|  | Airbag |  | Karosserie- verstärkung |  | Steuergerät |
|  | Gas- generator |  | Überroll- schutz |  | Batterie |
|  | Gurt- straffer |  | Gasdruck- dämpfer |  | Kraftstoff- tank |

NP300







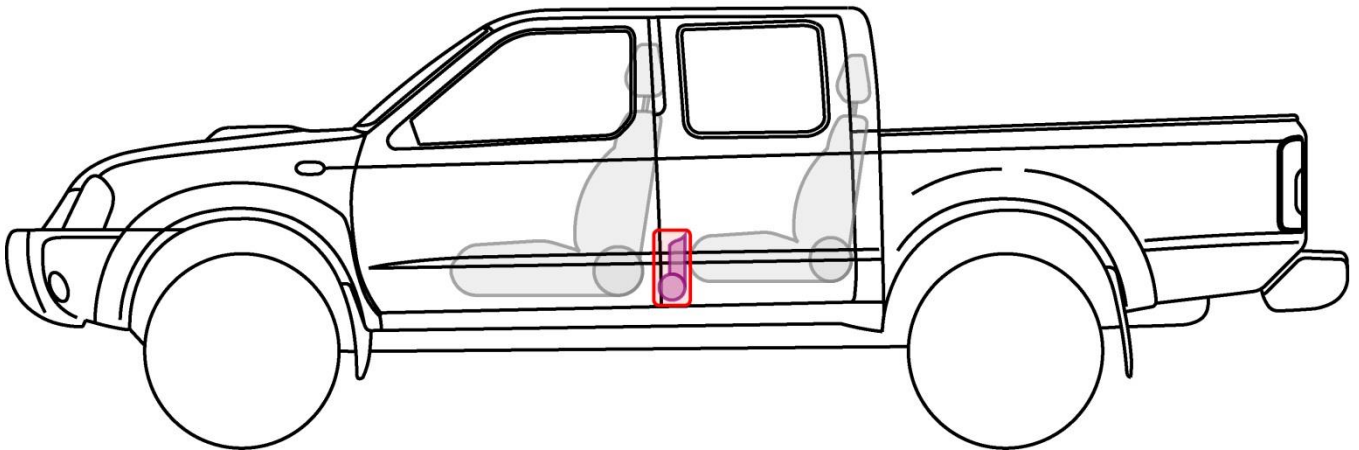
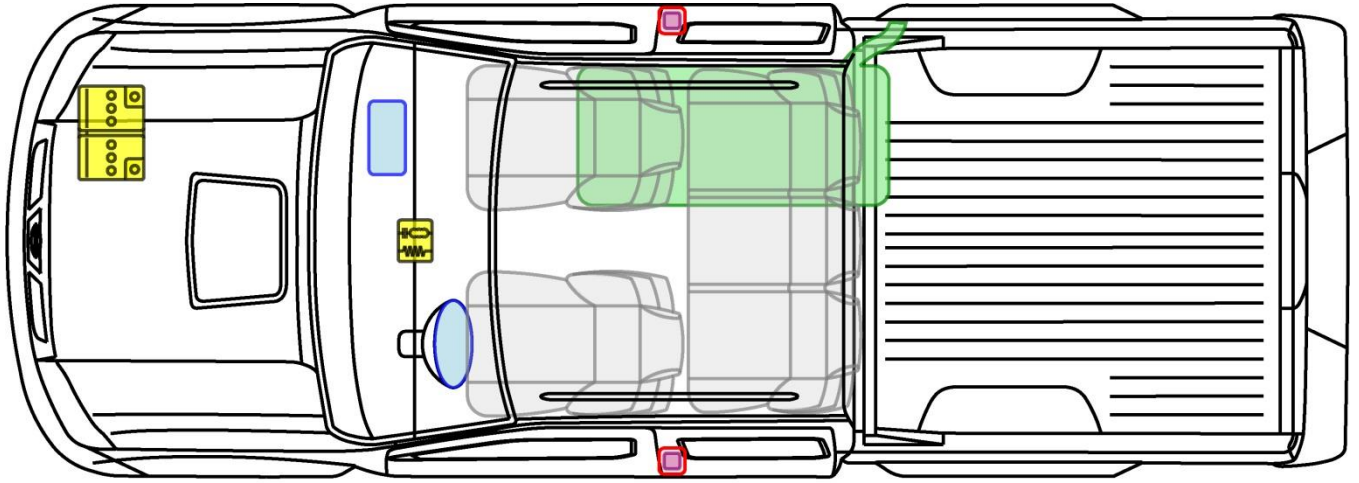

NP300 Crew Cab

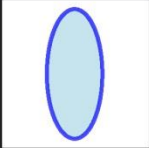
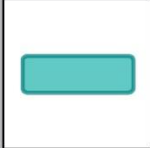
Typ: D22, 2008-2011

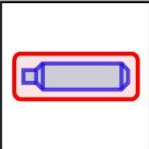

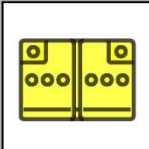
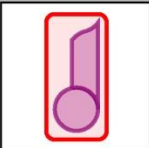
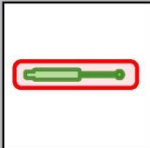
Legende

| | | | | | |
|---|-------------------|---|----------------------------|--|---------------------|
|  | Airbag |  | Karosserie- verstärkung |  | Steuergerät |
|  | Gas- generator |  | Überroll- schutz |  | Batterie |
|  | Gurt- straffer |  | Gasdruck- dämpfer |  | Kraftstoff- tank |

NP300







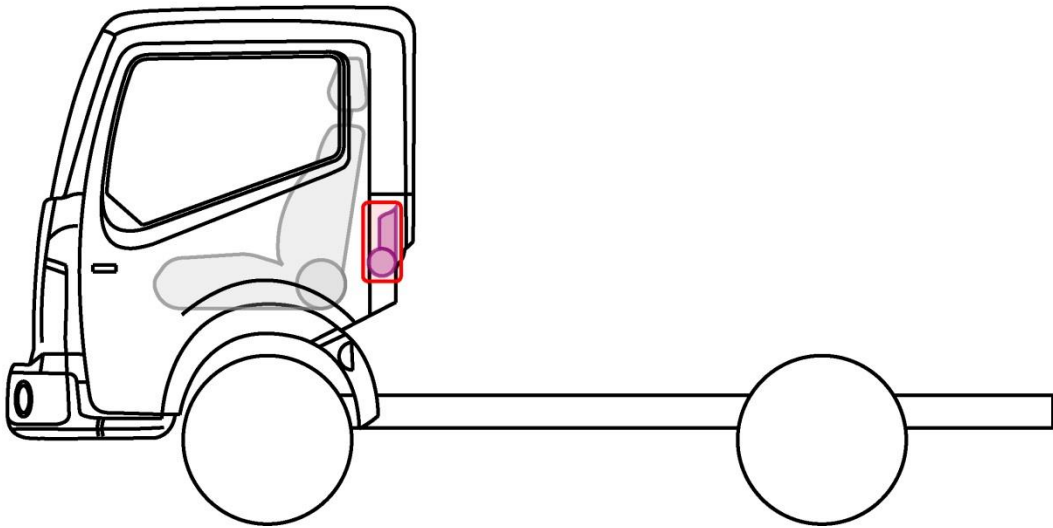
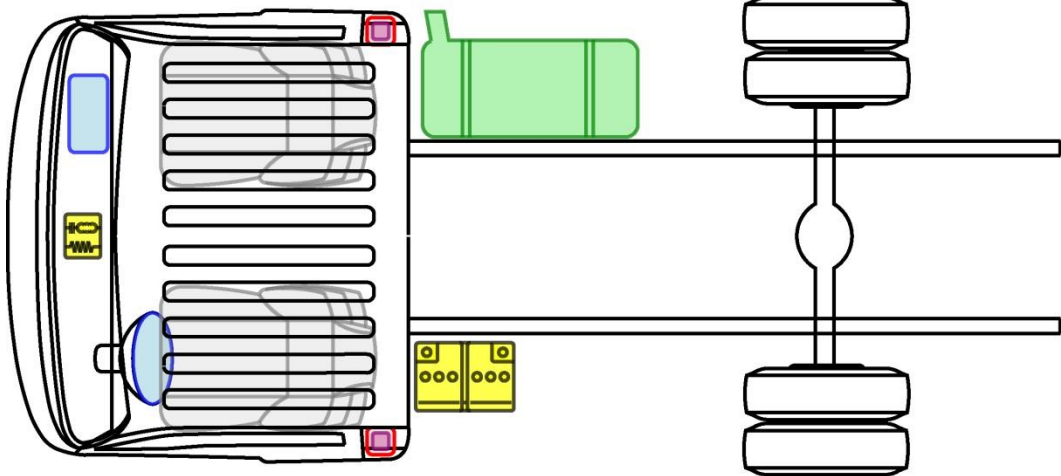

NT400 CABSTAR

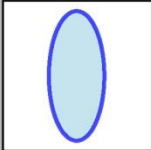
Typ: F24, 2006-

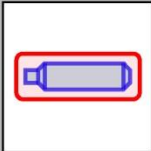

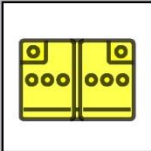
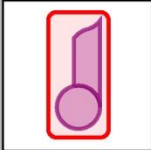
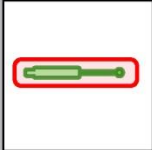
Legende

| | | | | | |
|---|-------------------|---|----------------------------|--|---------------------|
|  | Airbag |  | Karosserie- verstärkung |  | Steuergerät |
|  | Gas- generator |  | Überroll- schutz |  | Batterie |
|  | Gurt- straffer |  | Gasdruck- dämpfer |  | Kraftstoff- tank |

NT400



NV200

Typ: M20, 2009-

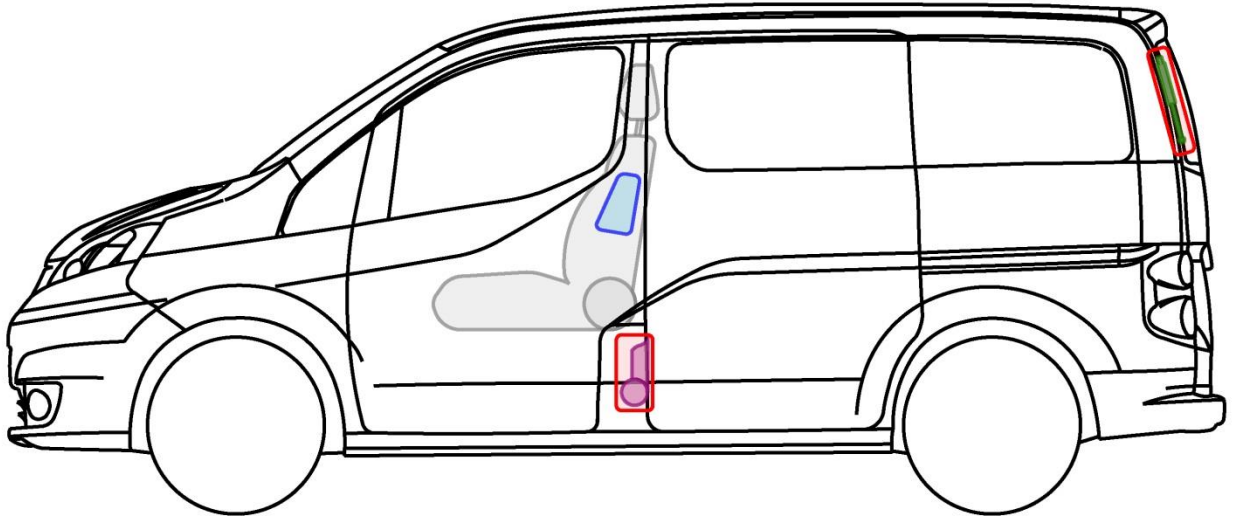
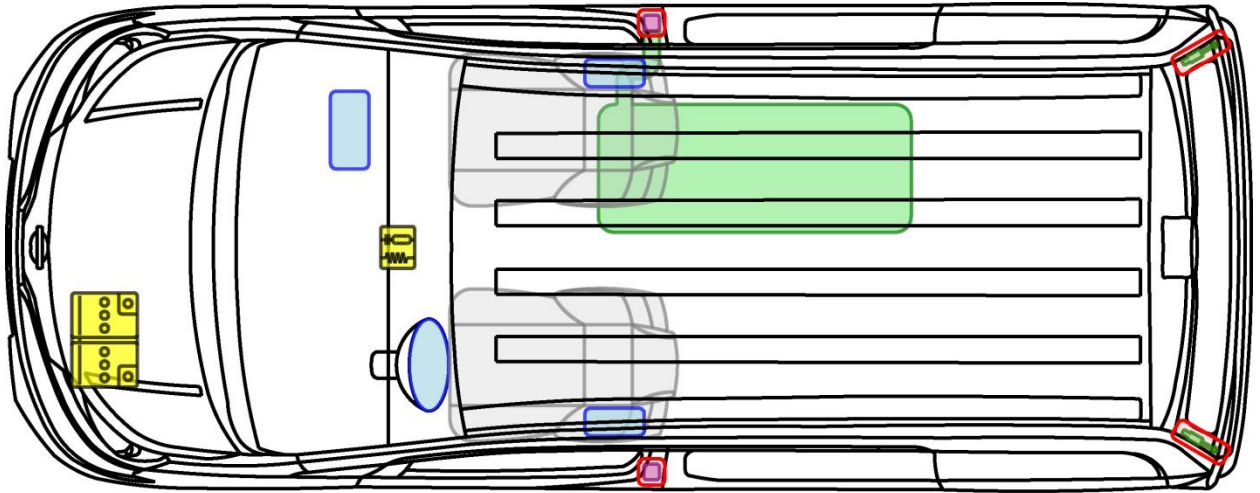

Legende

| | | | | | |
|--|-------------------|--|----------------------------|--|---------------------|
| | Airbag | | Karosserie- verstärkung | | Steuergerät |
| | Gas- generator | | Überroll- schutz | | Batterie |
| | Gurt- straffer | | Gasdruck- dämpfer | | Kraftstoff- tank |

NV200







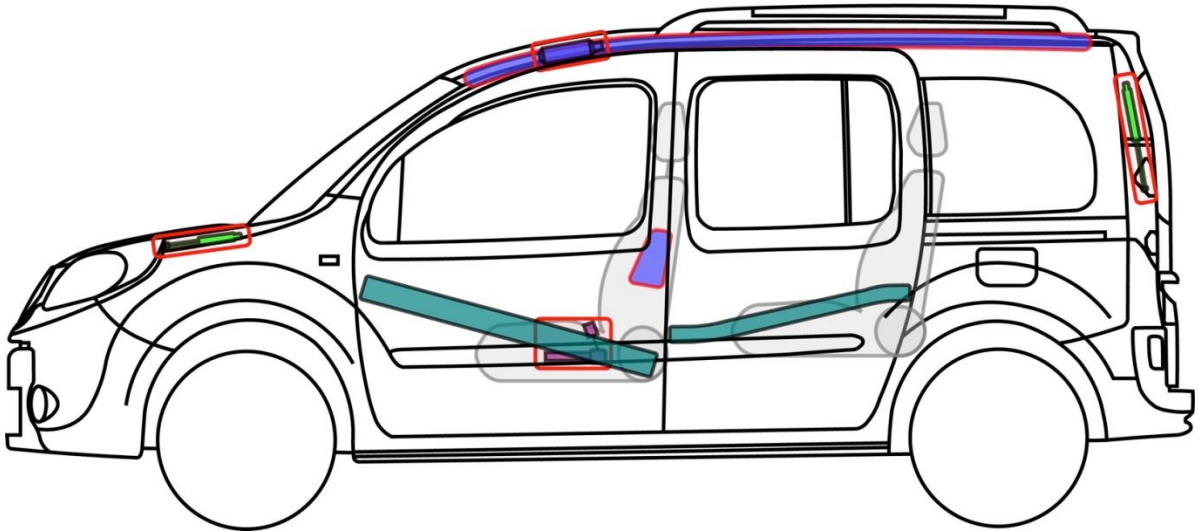
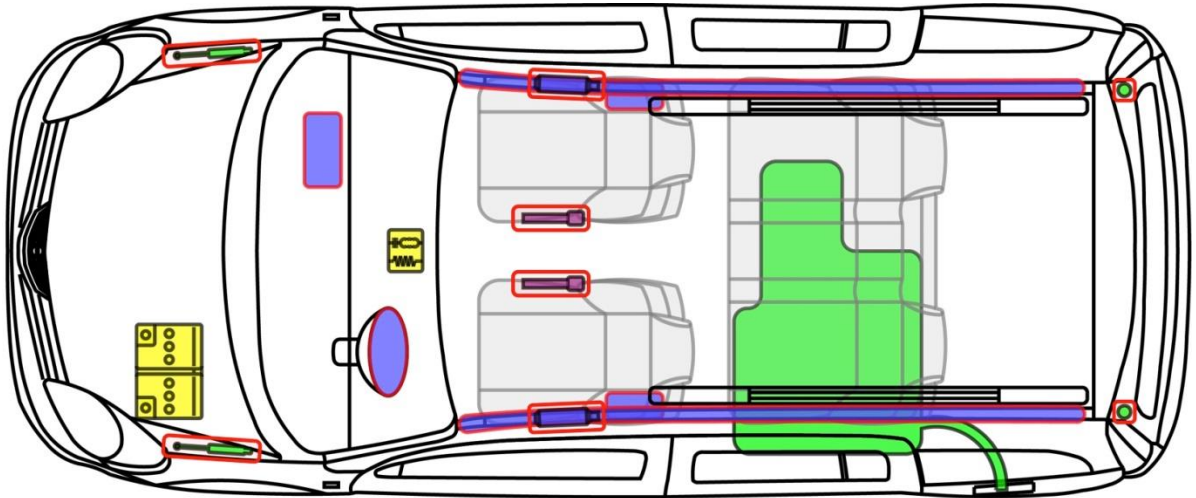

NV250 L1

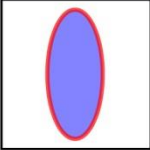
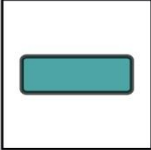
Typ: W, 2019-

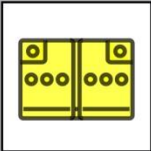

Legende

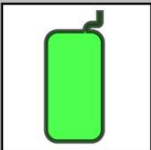
| | | | | | |
|---|-------------------|---|----------------------------|--|---------------------|
|  | Airbag |  | Karosserie- verstärkung |  | Steuergerät |
|  | Gas- generator |  | Überroll- schutz |  | Batterie |
|  | Gurt- straffer |  | Gasdruck- dämpfer |  | Kraftstoff- tank |

NV250







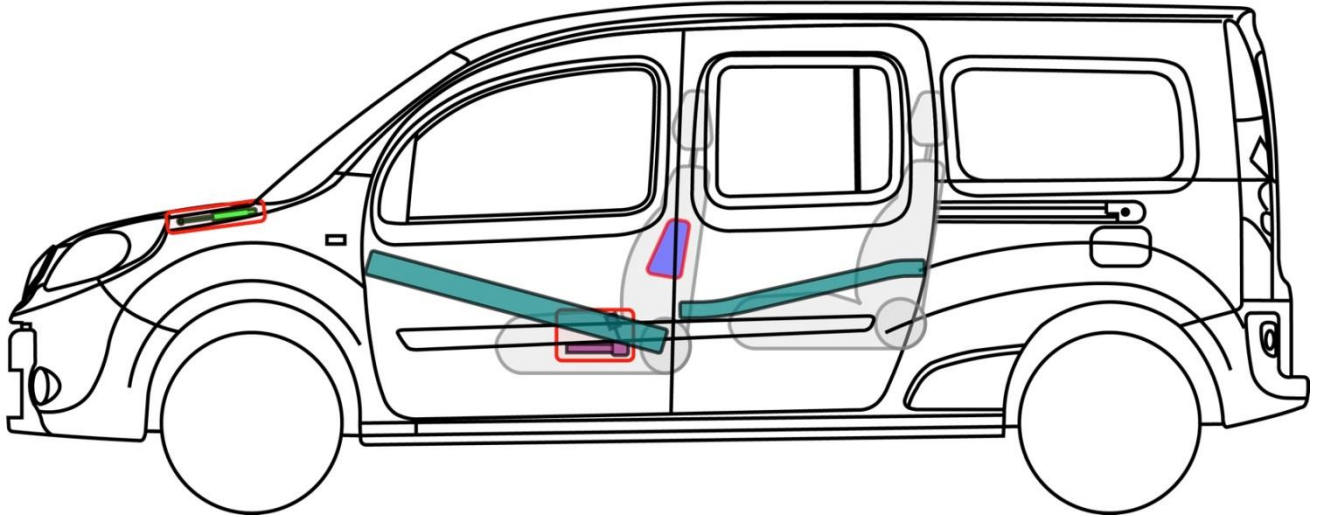
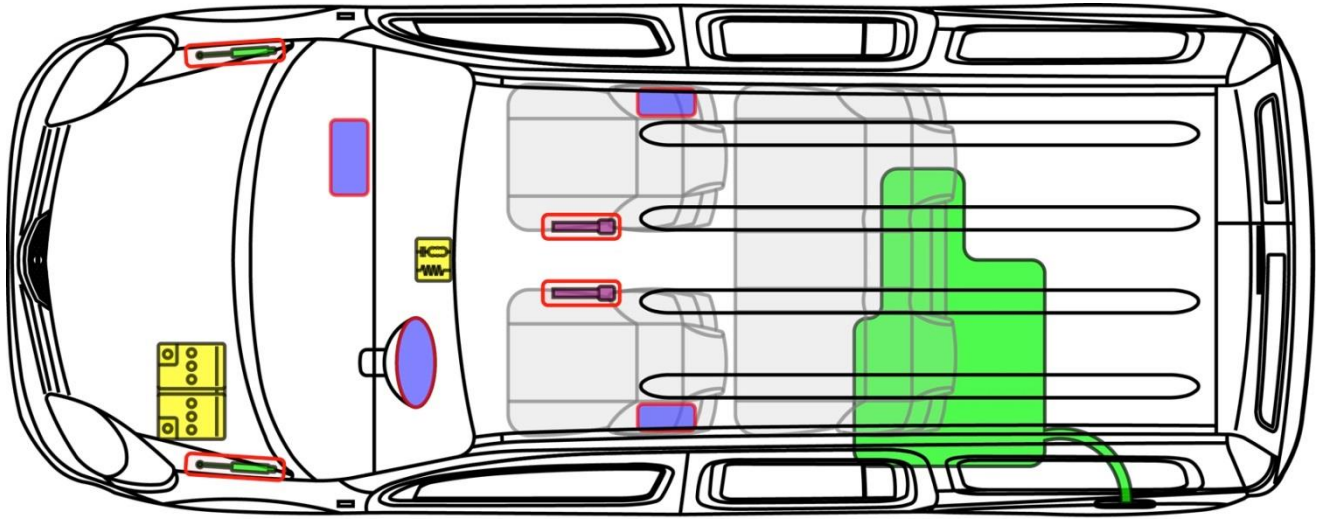

NV250 L2

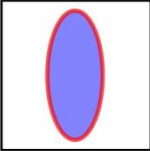
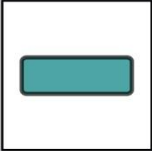
Typ: W, 2019-

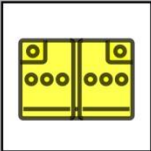

Legende

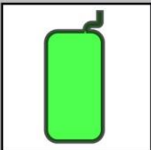
| | | | | | |
|---|-------------------|---|----------------------------|--|---------------------|
|  | Airbag |  | Karosserie- verstärkung |  | Steuergerät |
|  | Gas- generator |  | Überroll- schutz |  | Batterie |
|  | Gurt- straffer |  | Gasdruck- dämpfer |  | Kraftstoff- tank |

NV250







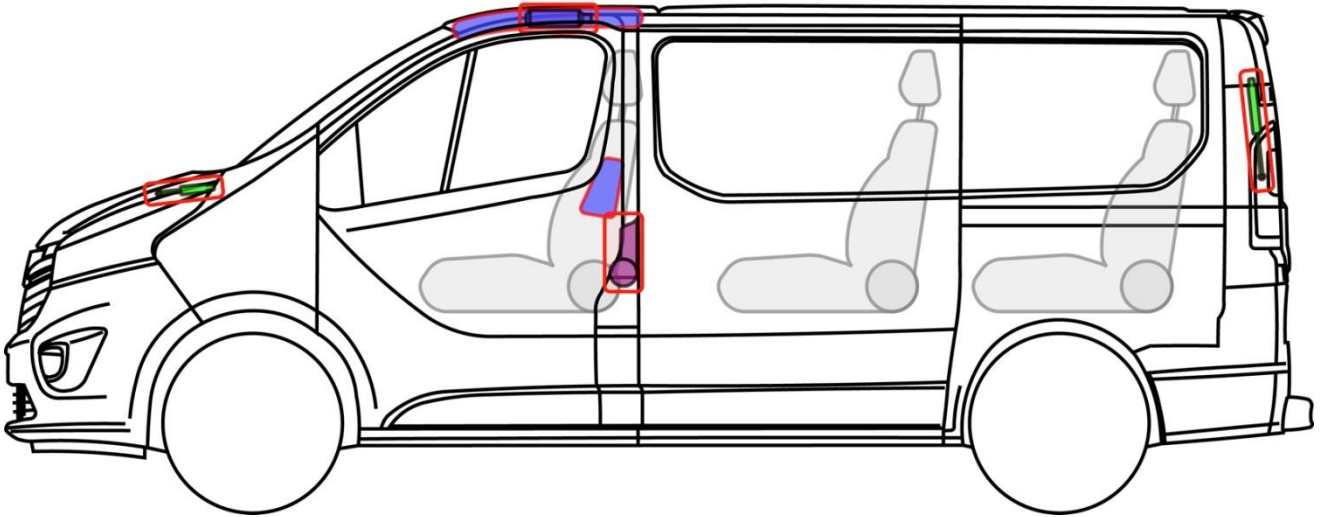
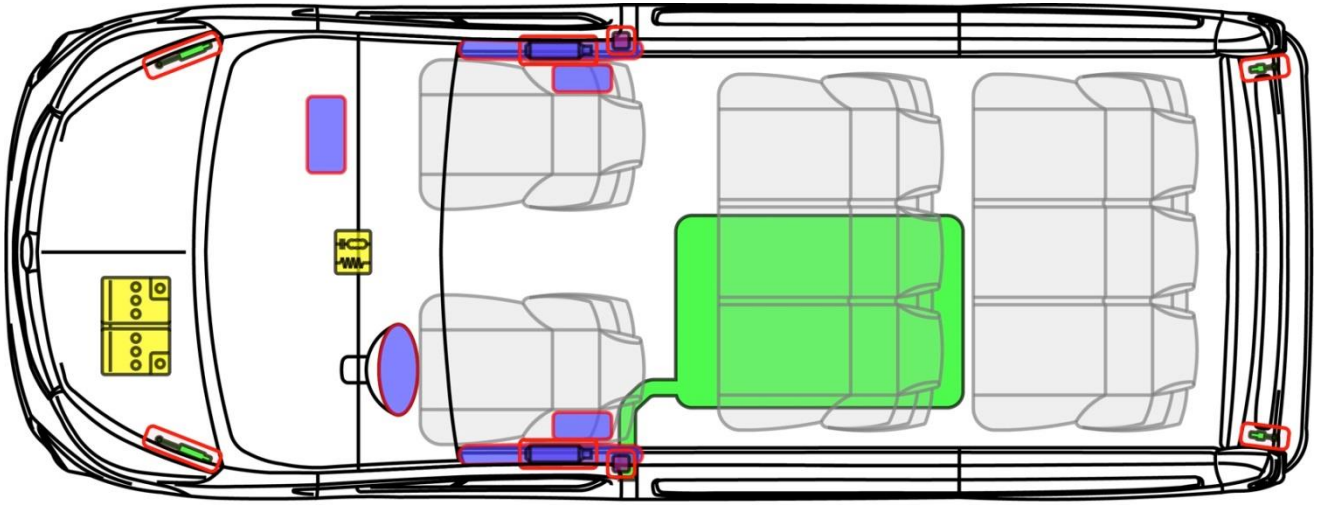

NV300

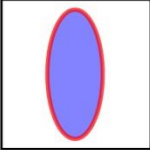
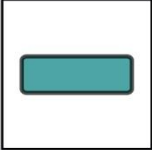
Typ: X82, 2016-

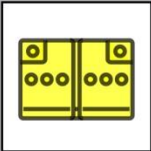

Legende

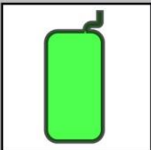
| | | | | | |
|---|---------------|---|------------------------|--|-----------------|
|  | Airbag |  | Karosserie-verstärkung |  | Steuergerät |
|  | Gas-generator |  | Überrollschutz |  | Batterie |
|  | Gurt-straffer |  | Gasdruck-dämpfer |  | Kraftstoff-tank |

NV300







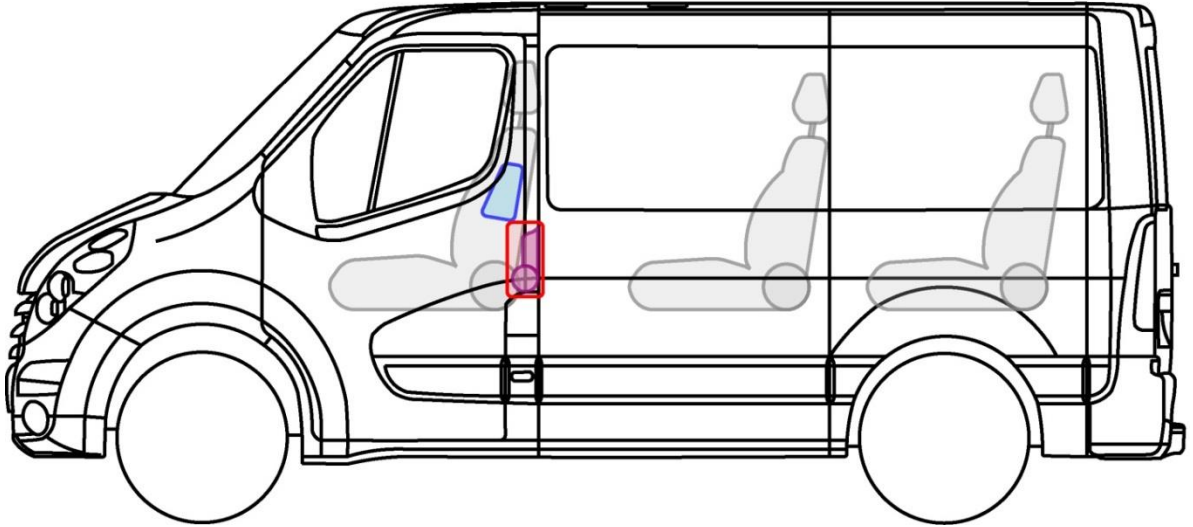
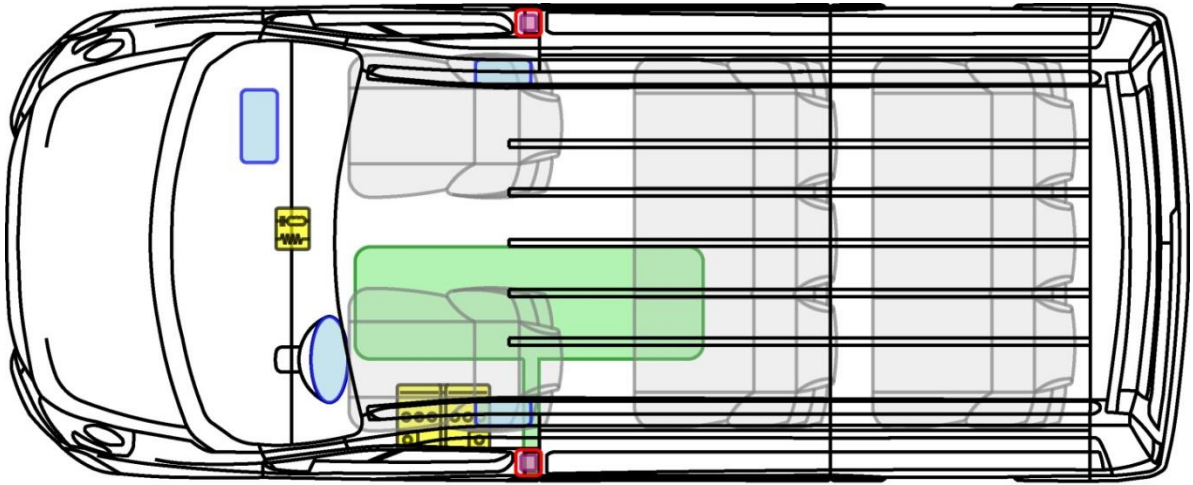

NV400

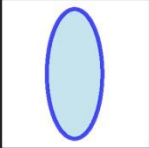
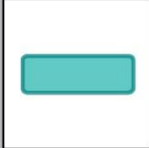
Typ: M9, 2011-

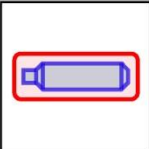

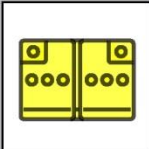
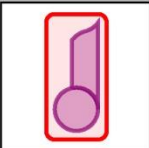
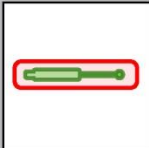
Legende

| | | | | | |
|---|-------------------|---|----------------------------|--|---------------------|
|  | Airbag |  | Karosserie- verstärkung |  | Steuergerät |
|  | Gas- generator |  | Überroll- schutz |  | Batterie |
|  | Gurt- straffer |  | Gasdruck- dämpfer |  | Kraftstoff- tank |

NV400



PATHFINDER

Typ: R51, 2005-

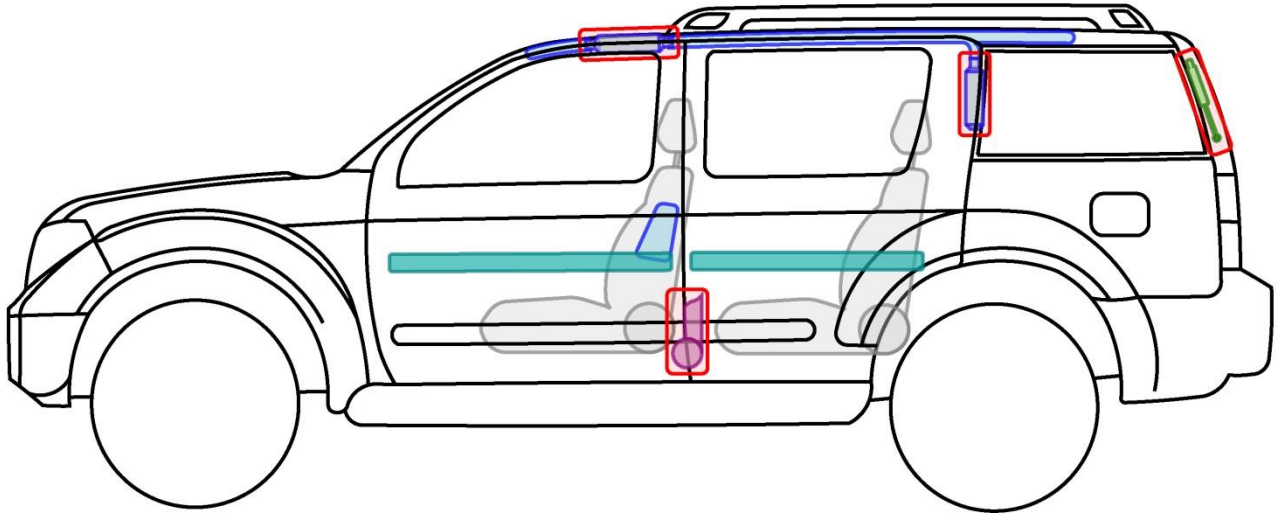
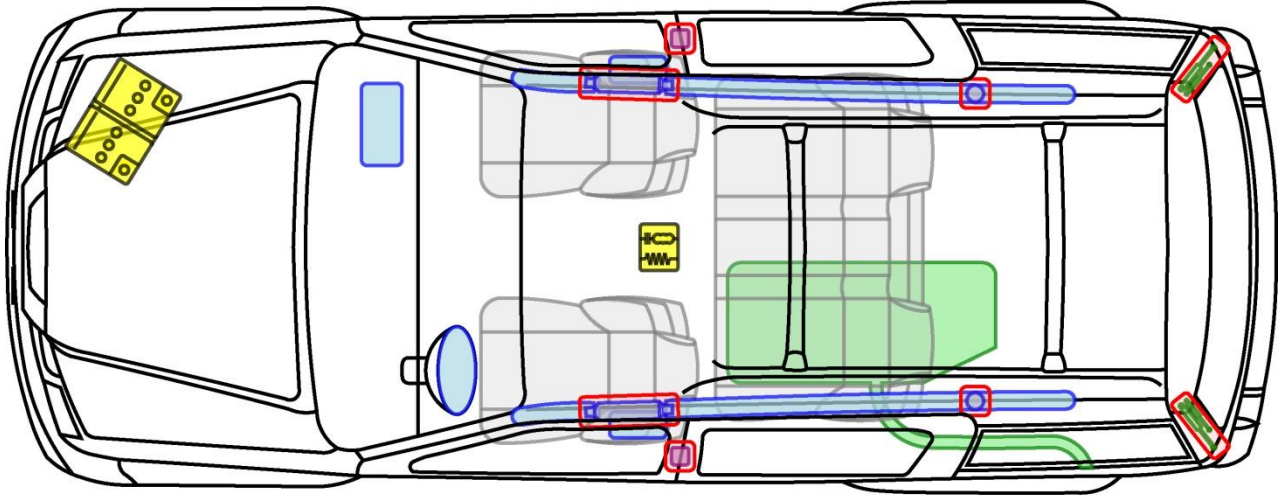

Legende

| | | | | | |
|--|-------------------|--|----------------------------|--|---------------------|
| | Airbag | | Karosserie- verstärkung | | Steuergerät |
| | Gas- generator | | Überroll- schutz | | Batterie |
| | Gurt- straffer | | Gasdruck- dämpfer | | Kraftstoff- tank |

PATHFINDER







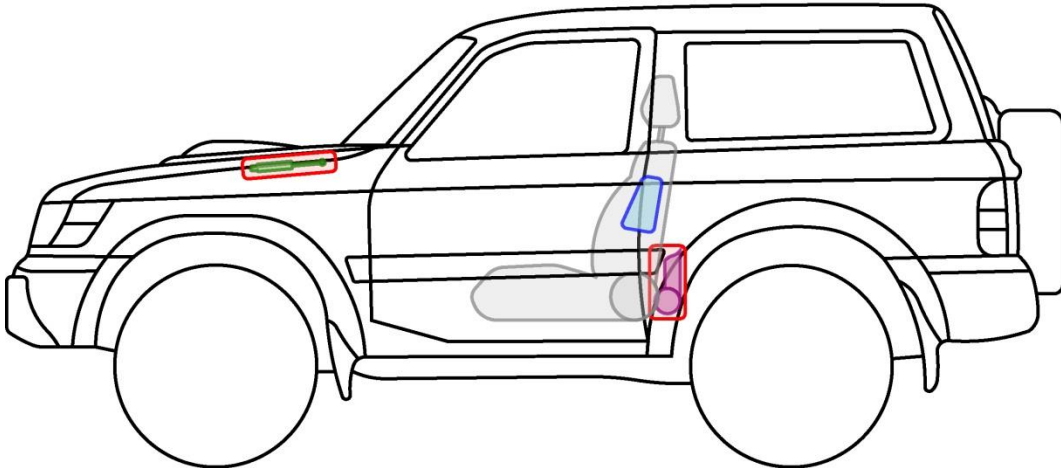
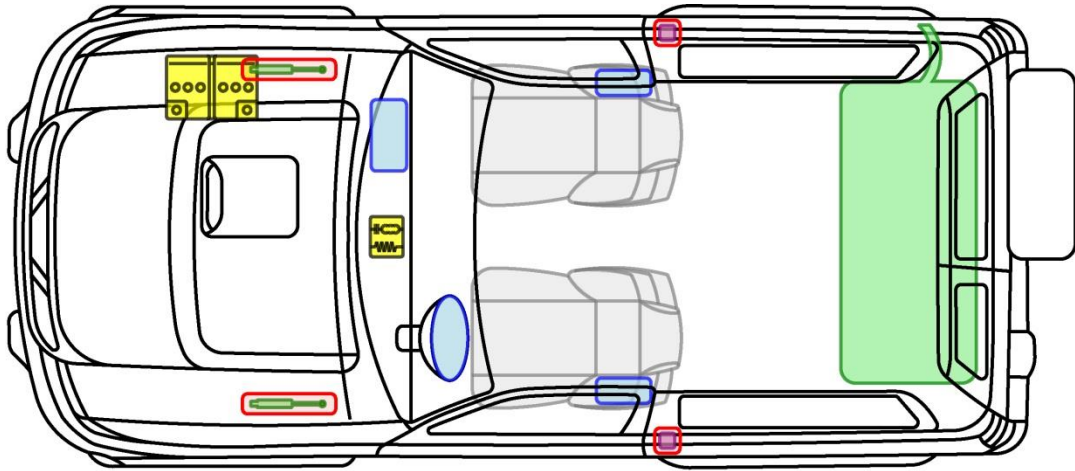

PATROL 3-Türer

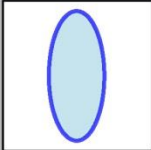
Typ: Y61, 2000-2009

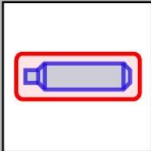

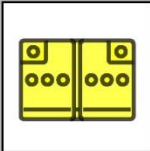
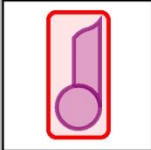
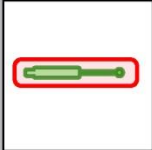
Legende

| | | | | | |
|---|-------------------|---|----------------------------|--|---------------------|
|  | Airbag |  | Karosserie- verstärkung |  | Steuergerät |
|  | Gas- generator |  | Überroll- schutz |  | Batterie |
|  | Gurt- straffer |  | Gasdruck- dämpfer |  | Kraftstoff- tank |

PATROL







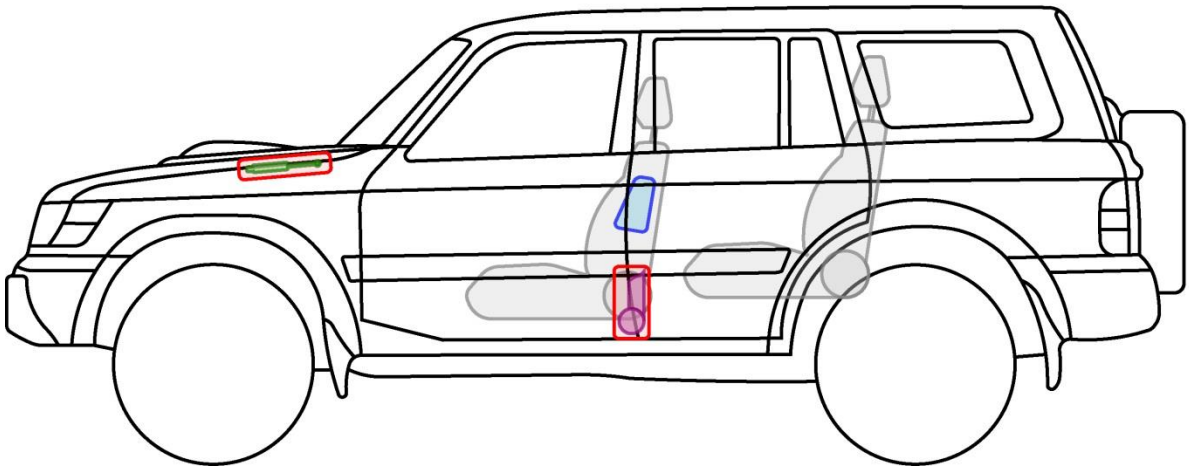
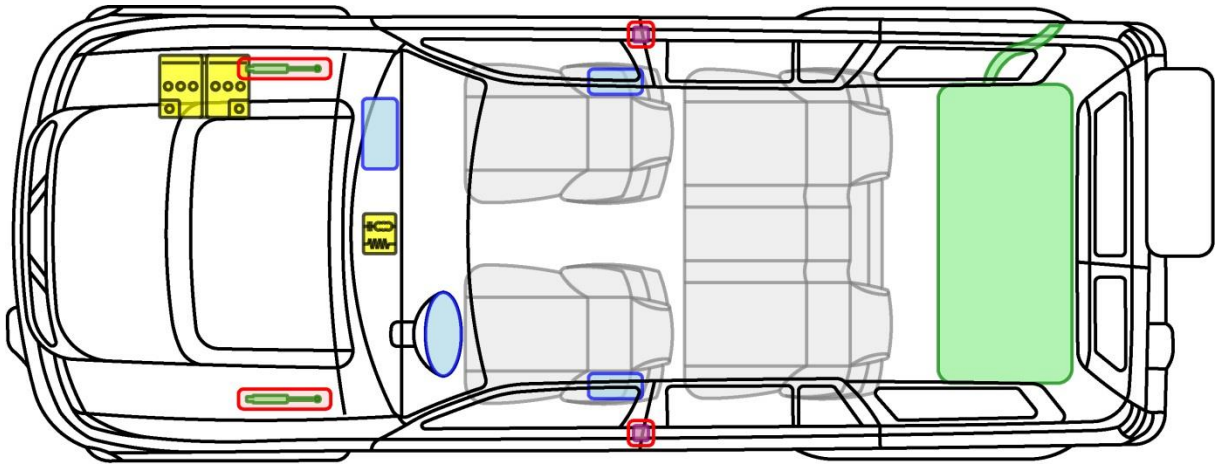

PATROL 5-Türer

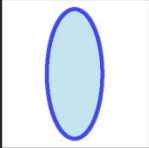
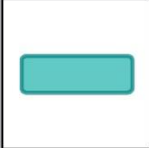
Typ: Y61, 2000-2009

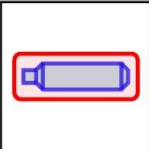

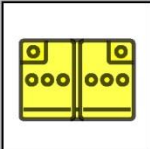
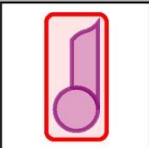
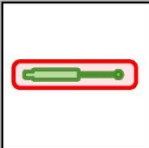
Legende

| | | | | | |
|---|-------------------|---|----------------------------|--|---------------------|
|  | Airbag |  | Karosserie- verstärkung |  | Steuergerät |
|  | Gas- generator |  | Überroll- schutz |  | Batterie |
|  | Gurt- straffer |  | Gasdruck- dämpfer |  | Kraftstoff- tank |

PATROL



PIXO

Typ: UA0, 2009-2013

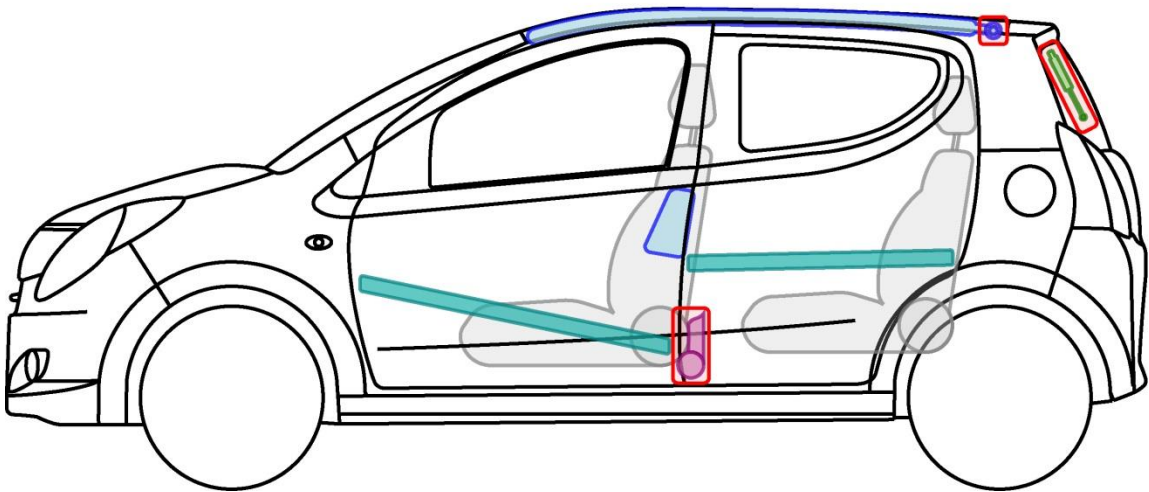
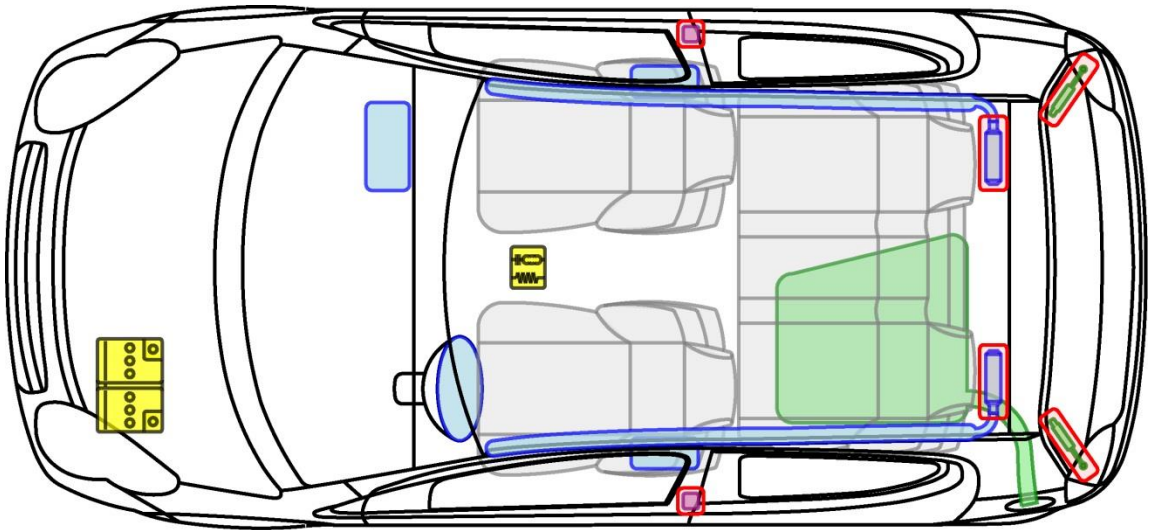

Legende

| | | | | | |
|--|-------------------|--|----------------------------|--|---------------------|
| | Airbag | | Karosserie- verstärkung | | Steuergerät |
| | Gas- generator | | Überroll- schutz | | Batterie |
| | Gurt- straffer | | Gasdruck- dämpfer | | Kraftstoff- tank |









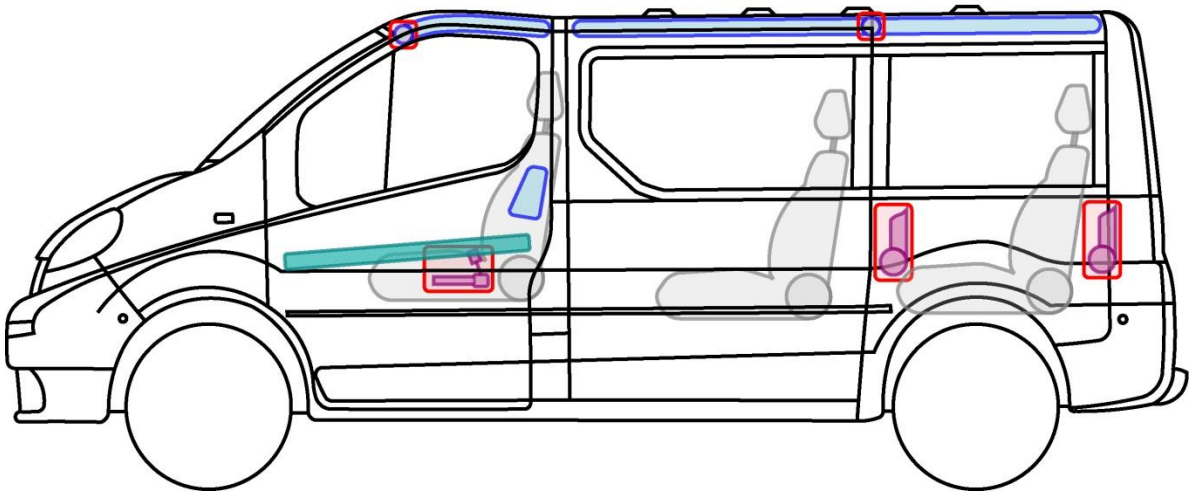
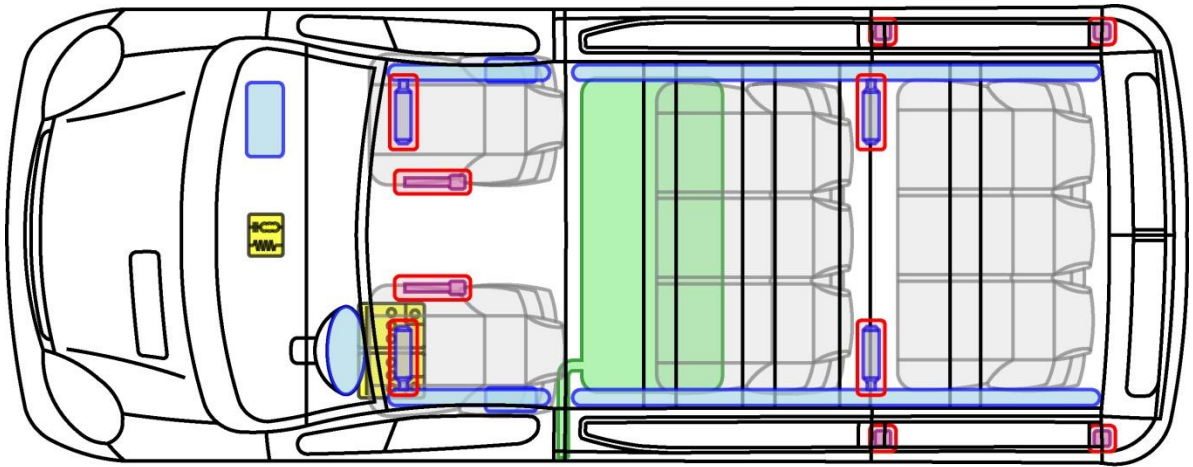

PRIMASTAR

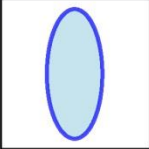
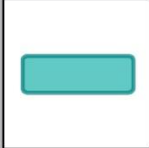
Typ: X83, 2003-

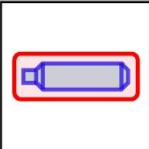

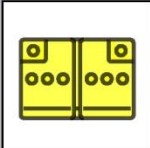
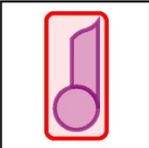
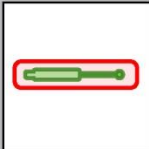
Legende

| | | | | | |
|---|-------------------|---|----------------------------|--|---------------------|
|  | Airbag |  | Karosserie- verstärkung |  | Steuergerät |
|  | Gas- generator |  | Überroll- schutz |  | Batterie |
|  | Gurt- straffer |  | Gasdruck- dämpfer |  | Kraftstoff- tank |

PRIMASTAR







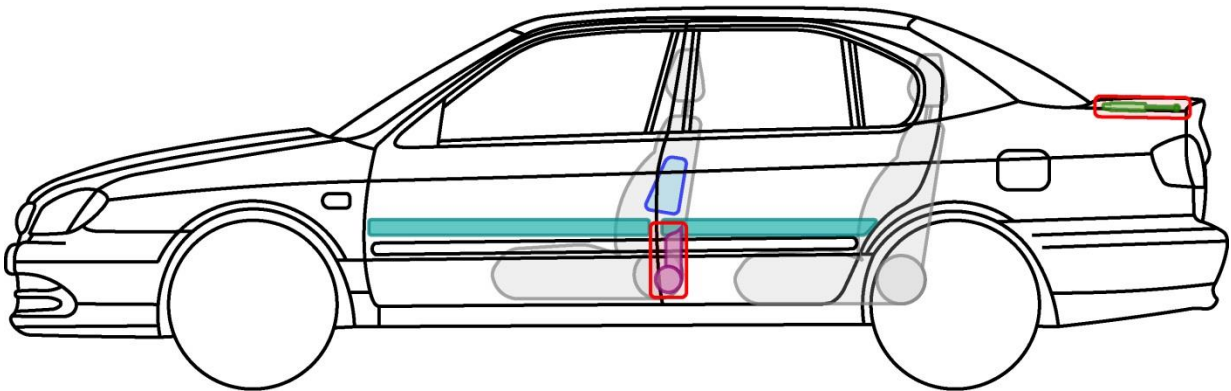
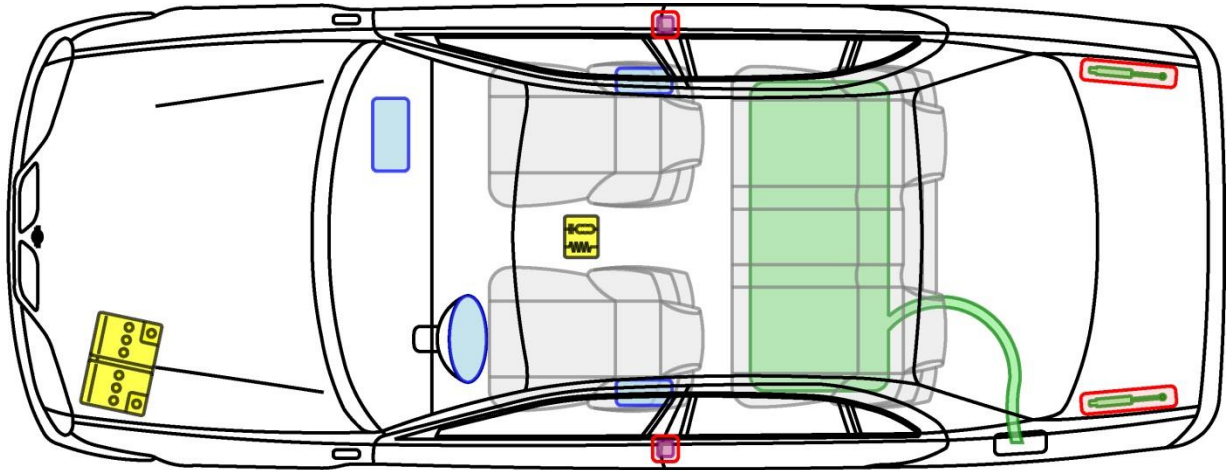

PRIMERA 4-Türer

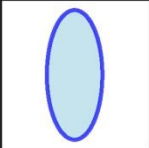
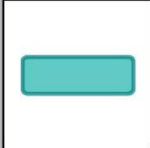
Typ: P11, 1994-2002

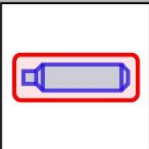

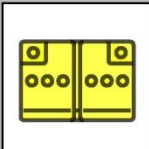
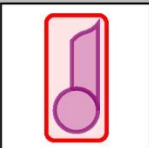
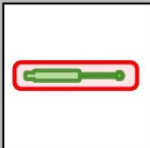
Legende

| | | | | | |
|---|-------------------|---|----------------------------|--|---------------------|
|  | Airbag |  | Karosserie- verstärkung |  | Steuergerät |
|  | Gas- generator |  | Überroll- schutz |  | Batterie |
|  | Gurt- straffer |  | Gasdruck- dämpfer |  | Kraftstoff- tank |





PRIMERA 5-Türer

Typ: P11, 1994-2002

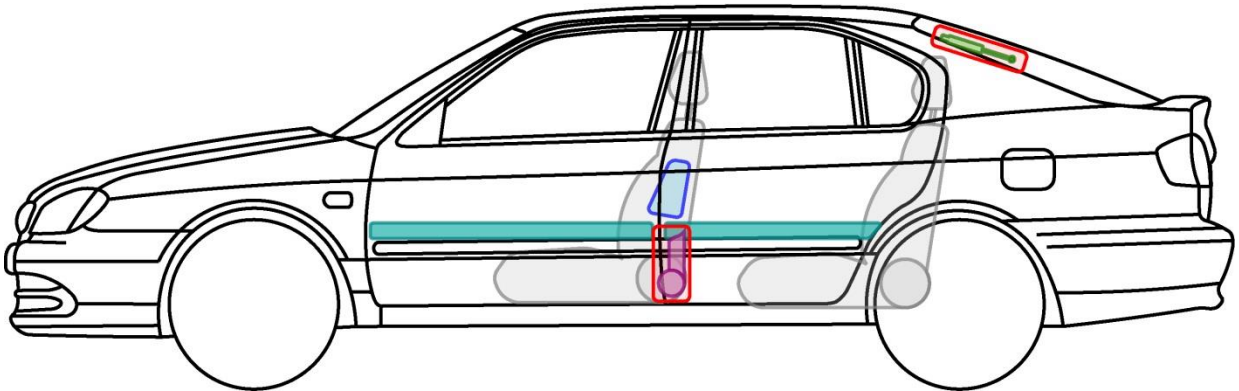
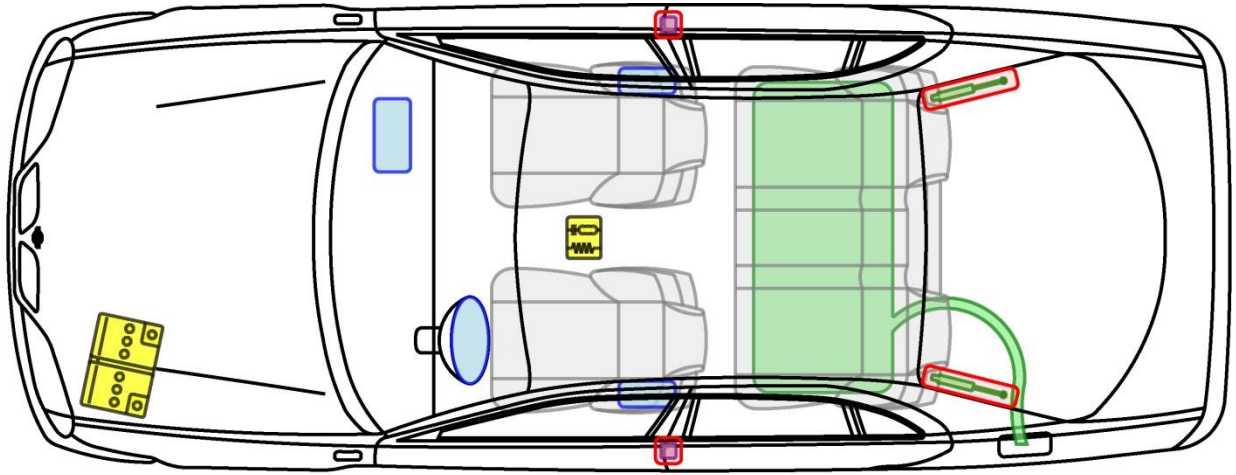

Legende

| | | | | | |
|--|-------------------|--|----------------------------|--|---------------------|
| | Airbag | | Karosserie- verstärkung | | Steuergerät |
| | Gas- generator | | Überroll- schutz | | Batterie |
| | Gurt- straffer | | Gasdruck- dämpfer | | Kraftstoff- tank |





PRIMERA Kombi

Typ: P11, 1994-2002

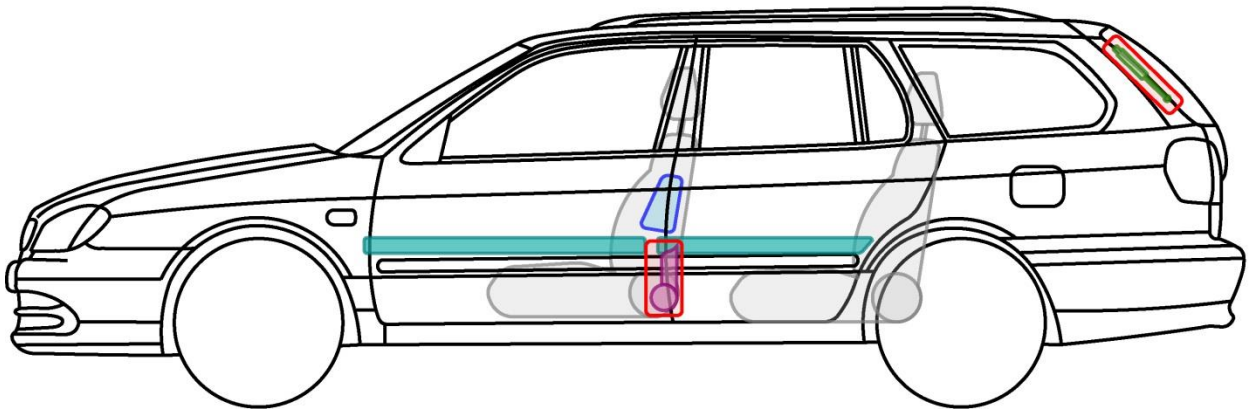
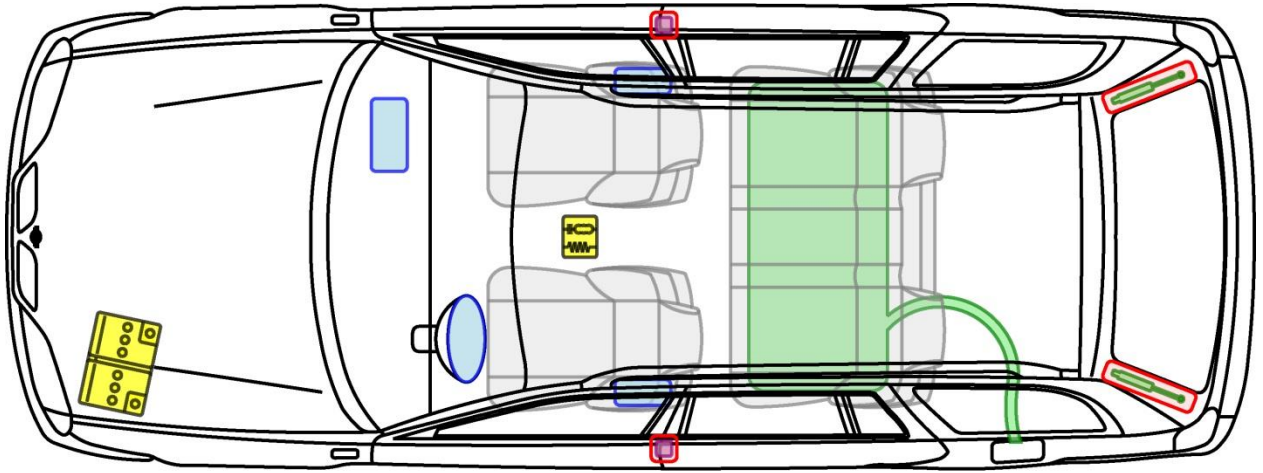

Legende

| | | | | | |
|--|-------------------|--|----------------------------|--|---------------------|
| | Airbag | | Karosserie- verstärkung | | Steuergerät |
| | Gas- generator | | Überroll- schutz | | Batterie |
| | Gurt- straffer | | Gasdruck- dämpfer | | Kraftstoff- tank |

PRIMERA







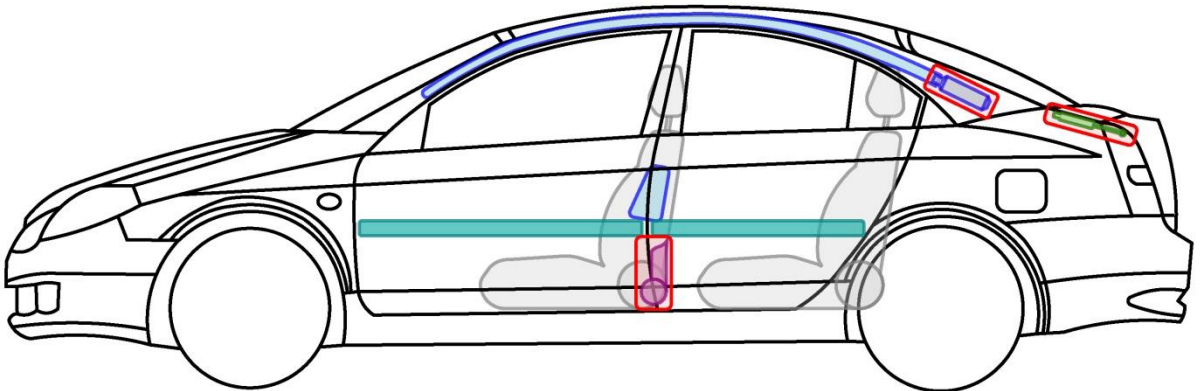
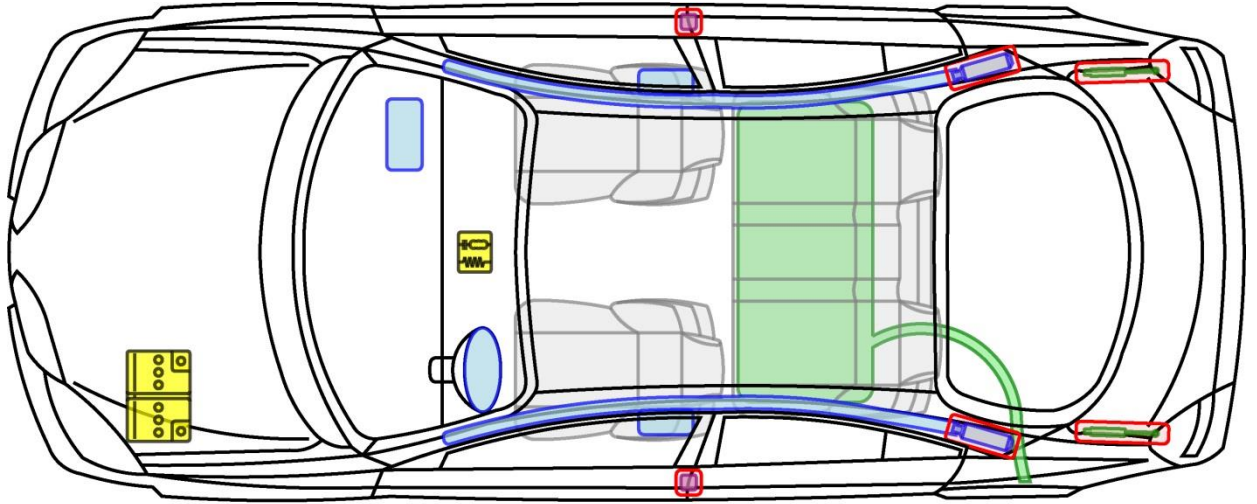

PRIMERA 4-Türer

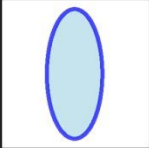
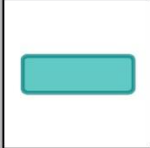
Typ: P12, 2002-2008

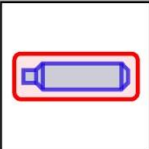

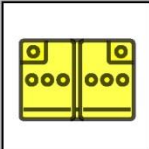
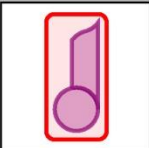
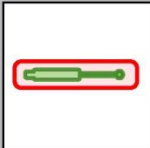
Legende

| | | | | | |
|---|-------------------|---|----------------------------|--|---------------------|
|  | Airbag |  | Karosserie- verstärkung |  | Steuergerät |
|  | Gas- generator |  | Überroll- schutz |  | Batterie |
|  | Gurt- straffer |  | Gasdruck- dämpfer |  | Kraftstoff- tank |

PRIMERA







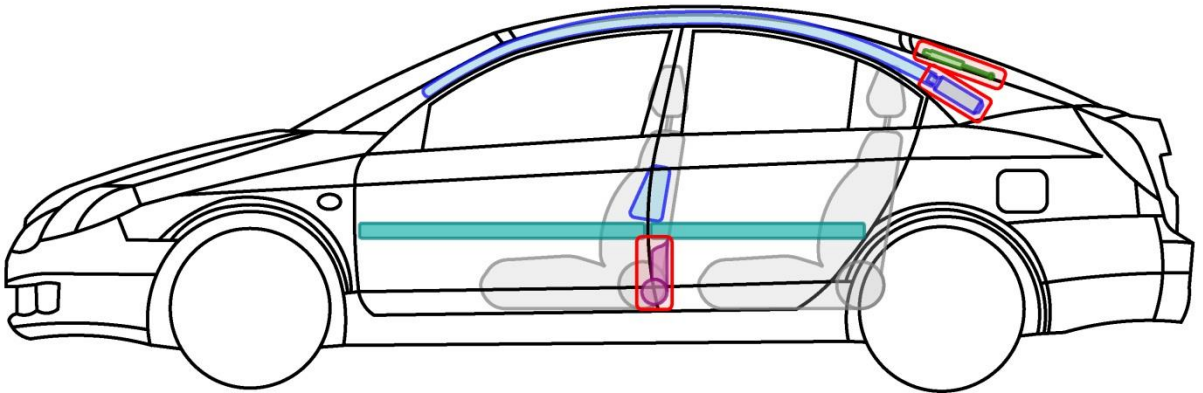
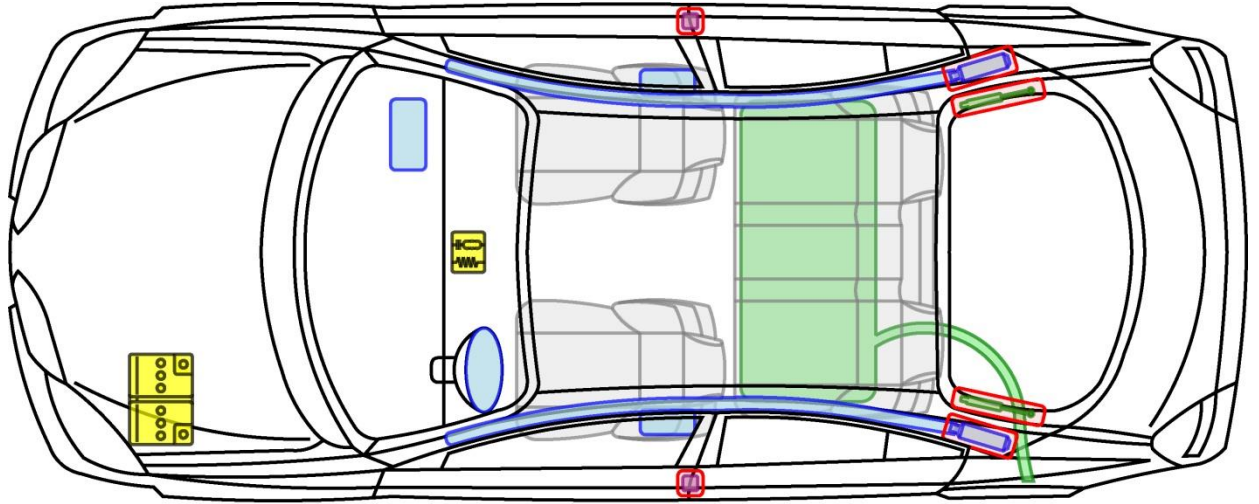

PRIMERA 5-Türer

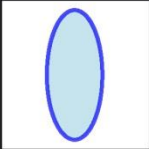
Typ: P12, 2002-2008

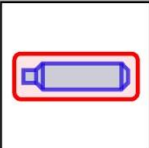

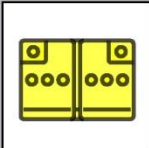
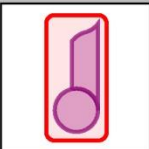
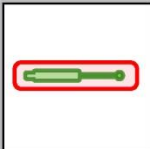
Legende

| | | | | | |
|---|-------------------|---|----------------------------|--|---------------------|
|  | Airbag |  | Karosserie- verstärkung |  | Steuergerät |
|  | Gas- generator |  | Überroll- schutz |  | Batterie |
|  | Gurt- straffer |  | Gasdruck- dämpfer |  | Kraftstoff- tank |

PRIMERA







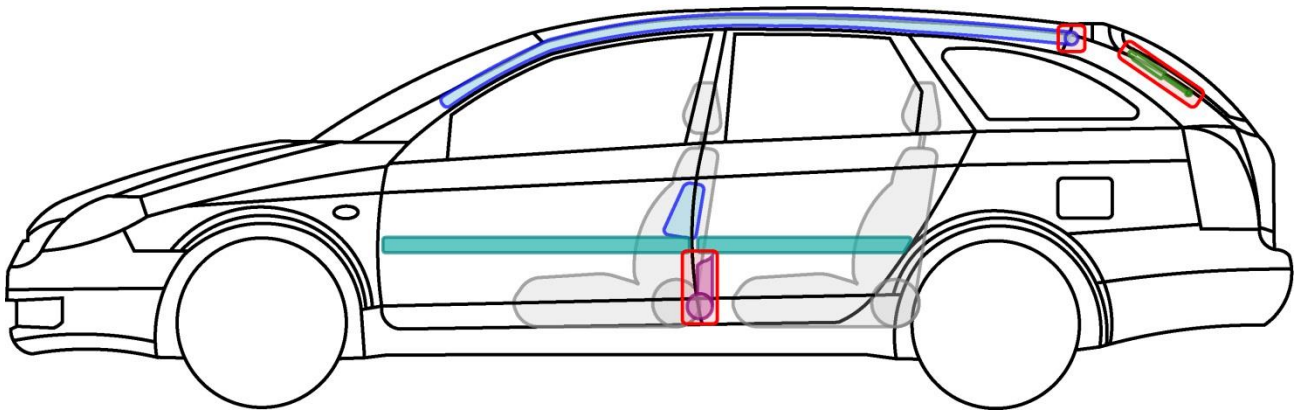
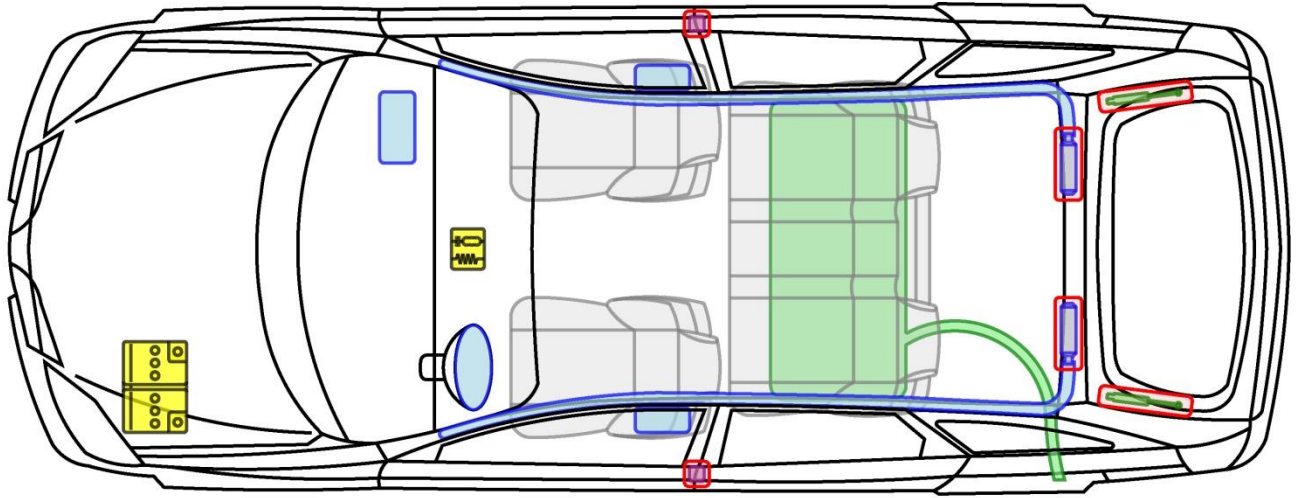

PRIMERA Kombi

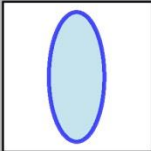
Typ: P12, 2002-2008

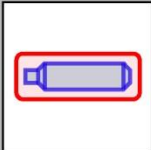

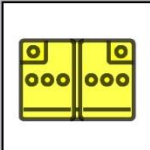
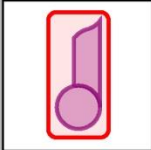
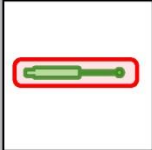
Legende

| | | | | | |
|---|-------------------|---|----------------------------|--|---------------------|
|  | Airbag |  | Karosserie- verstärkung |  | Steuergerät |
|  | Gas- generator |  | Überroll- schutz |  | Batterie |
|  | Gurt- straffer |  | Gasdruck- dämpfer |  | Kraftstoff- tank |

PRIMERA







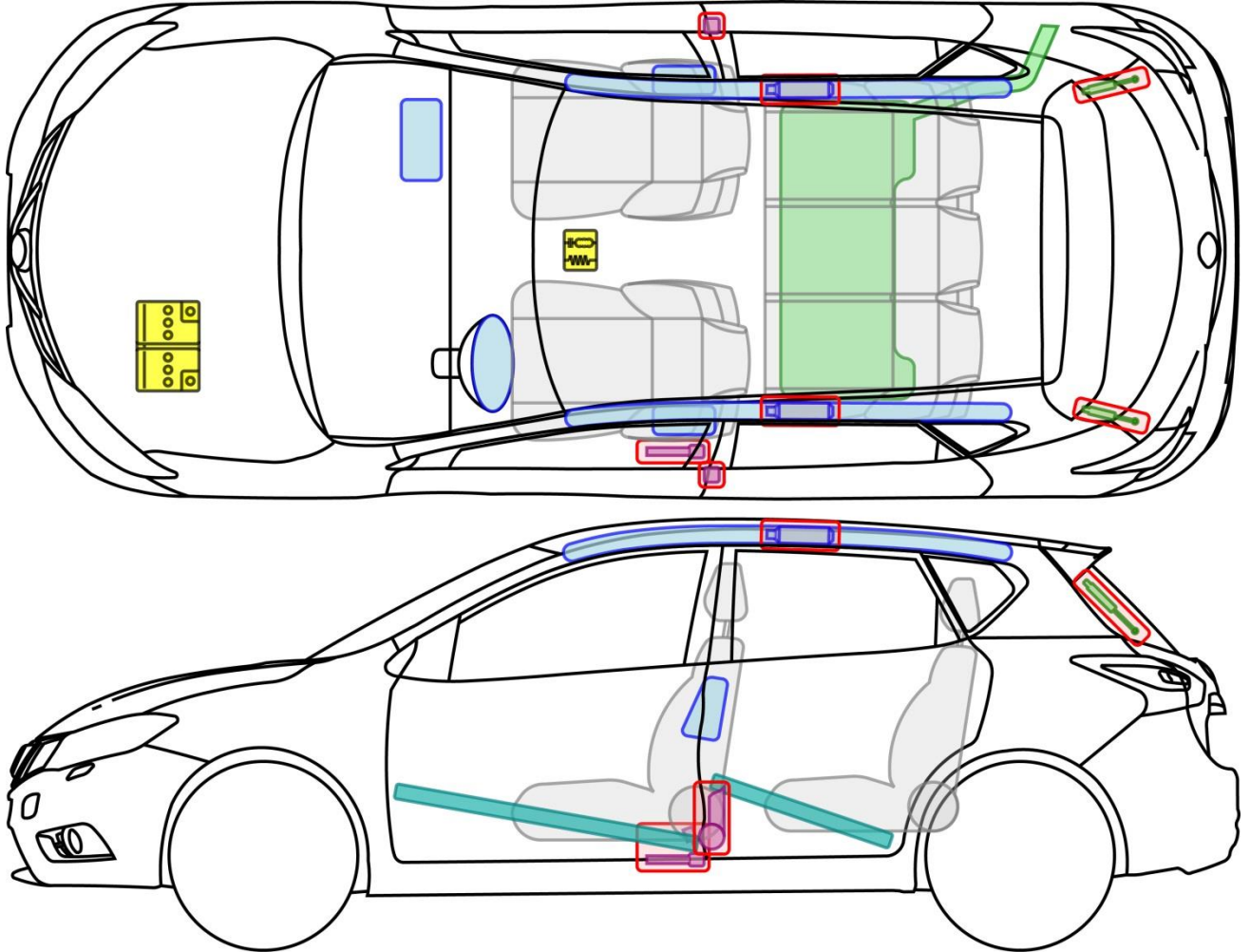

PULSAR

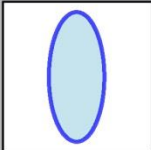
Typ: C13, 2014-

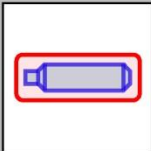

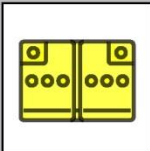
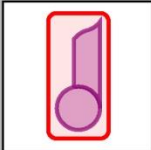
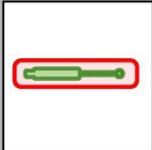
Legende

| | | | | | |
|---|-------------------|---|----------------------------|--|---------------------|
|  | Airbag |  | Karosserie- verstärkung |  | Steuergerät |
|  | Gas- generator |  | Überroll- schutz |  | Batterie |
|  | Gurt- straffer |  | Gasdruck- dämpfer |  | Kraftstoff- tank |

PULSAR





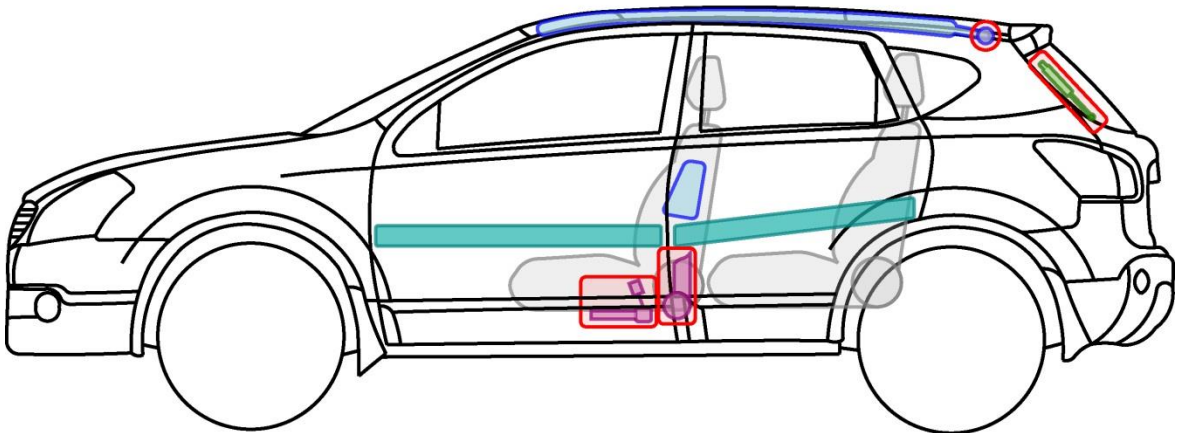
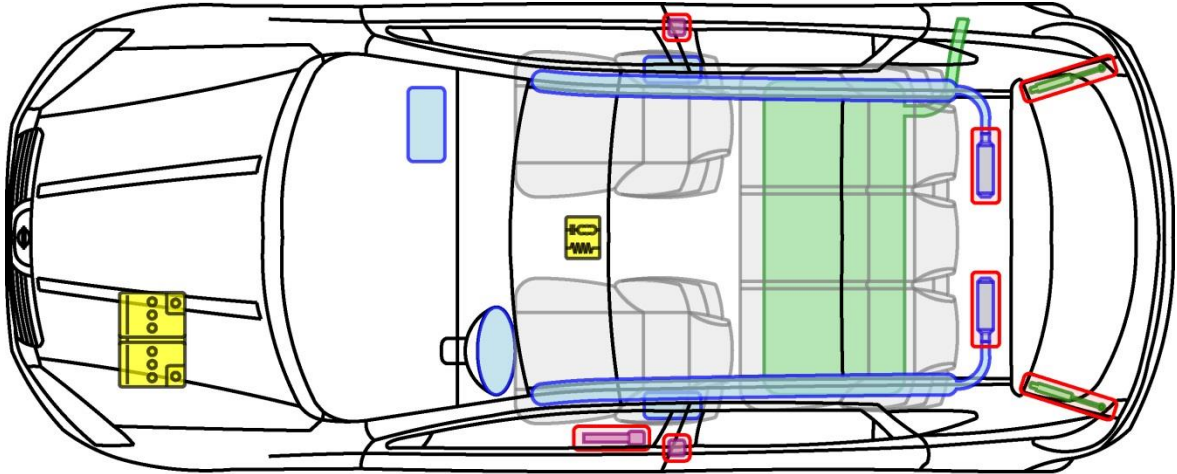

QASHQAI

Typ: J10, 2007-2014

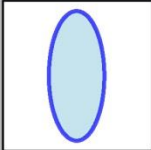

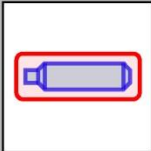
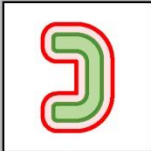
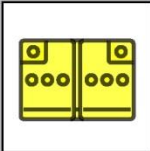
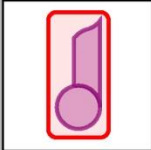
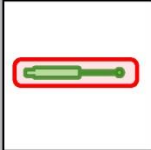
Legende

| | | | | | |
|---|-------------------|---|----------------------------|--|---------------------|
|  | Airbag |  | Karosserie- verstärkung |  | Steuergerät |
|  | Gas- generator |  | Überroll- schutz |  | Batterie |
|  | Gurt- straffer |  | Gasdruck- dämpfer |  | Kraftstoff- tank |

QASHQAI







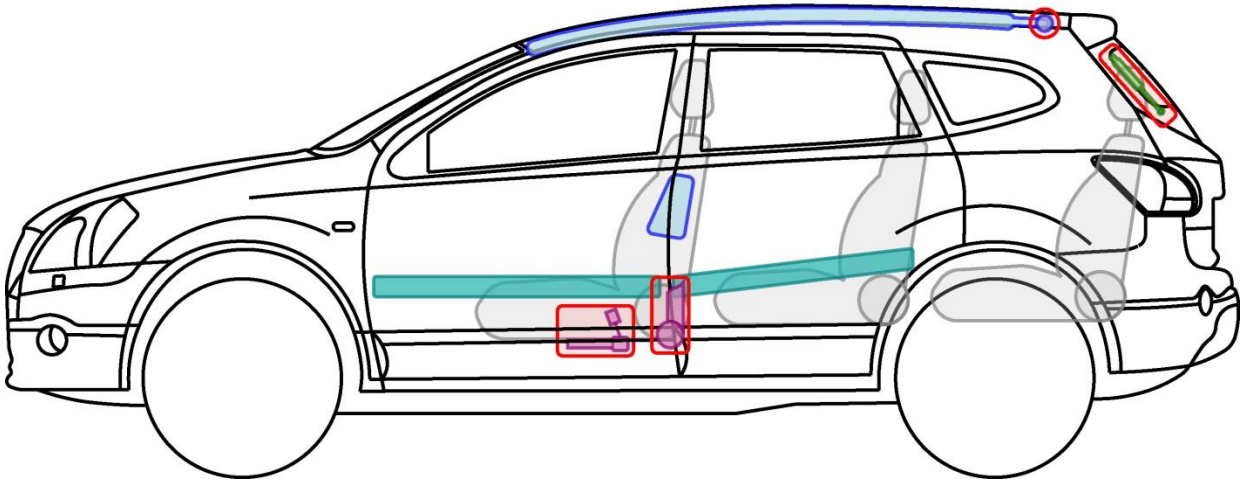
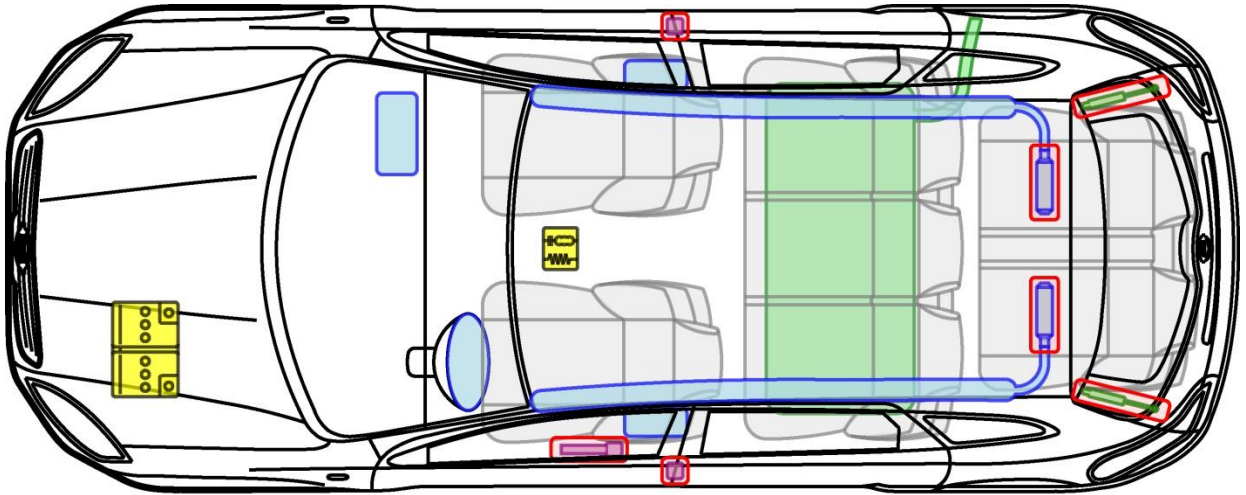

QASHQAI+2

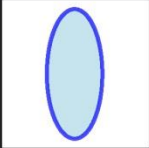
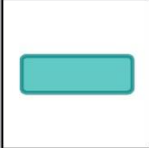
Typ: J10, 2008-2014

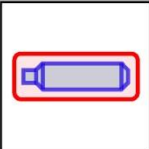

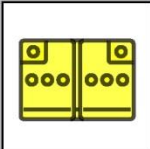
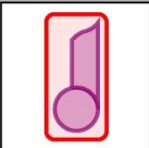
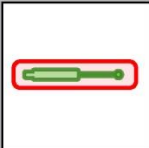
Legende

| | | | | | |
|---|-------------------|---|----------------------------|--|---------------------|
|  | Airbag |  | Karosserie- verstärkung |  | Steuergerät |
|  | Gas- generator |  | Überroll- schutz |  | Batterie |
|  | Gurt- straffer |  | Gasdruck- dämpfer |  | Kraftstoff- tank |

QASHQAI+2







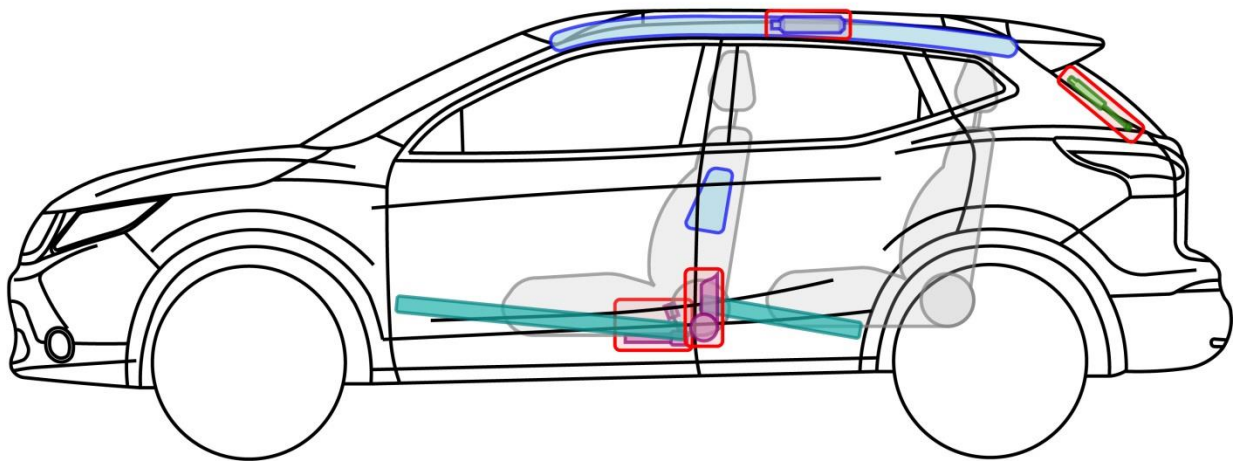
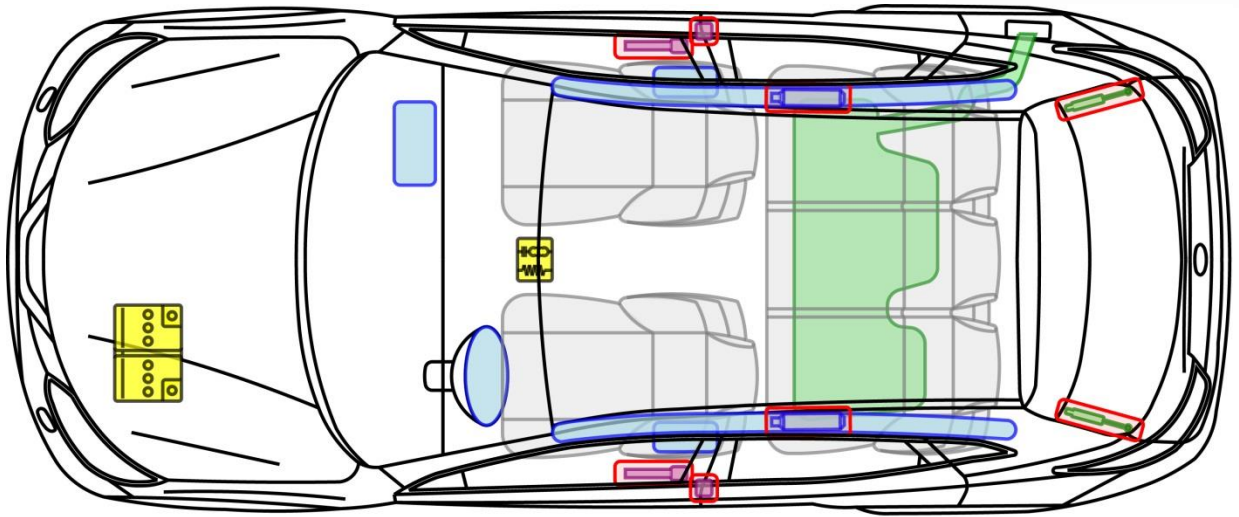

QASHQAI

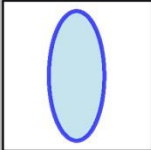
Typ: J11, 2014-

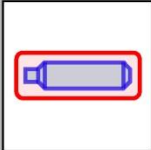

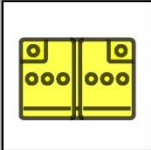
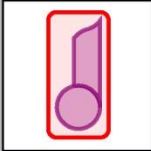
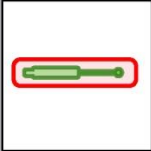
Legende

| | | | | | |
|---|-------------------|---|----------------------------|--|---------------------|
|  | Airbag |  | Karosserie- verstärkung |  | Steuergerät |
|  | Gas- generator |  | Überroll- schutz |  | Batterie |
|  | Gurt- straffer |  | Gasdruck- dämpfer |  | Kraftstoff- tank |

QASHQAI



TIIDA

Typ: C11, 2006-2011

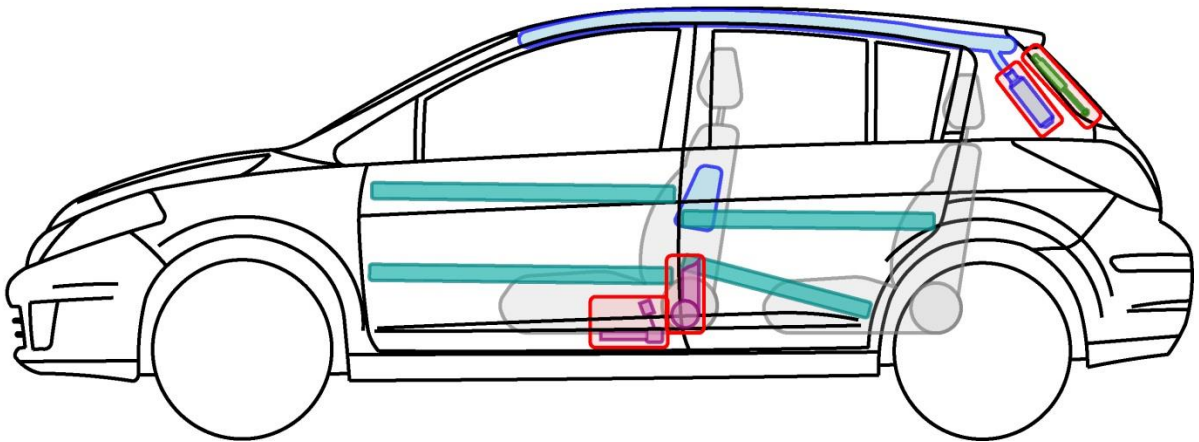
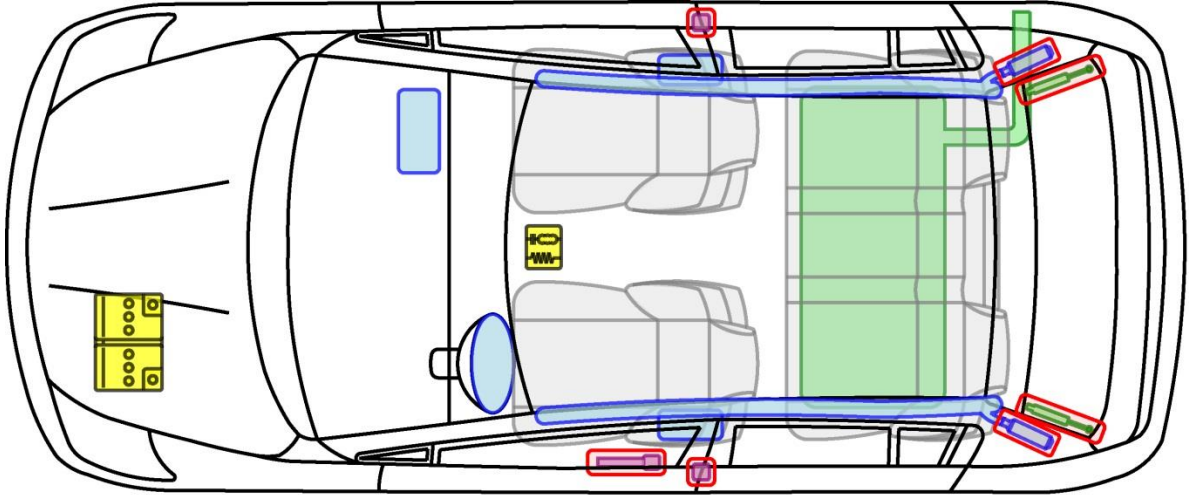

Legende

| | | | | | |
|--|-------------------|--|----------------------------|--|---------------------|
| | Airbag | | Karosserie- verstärkung | | Steuergerät |
| | Gas- generator | | Überroll- schutz | | Batterie |
| | Gurt- straffer | | Gasdruck- dämpfer | | Kraftstoff- tank |









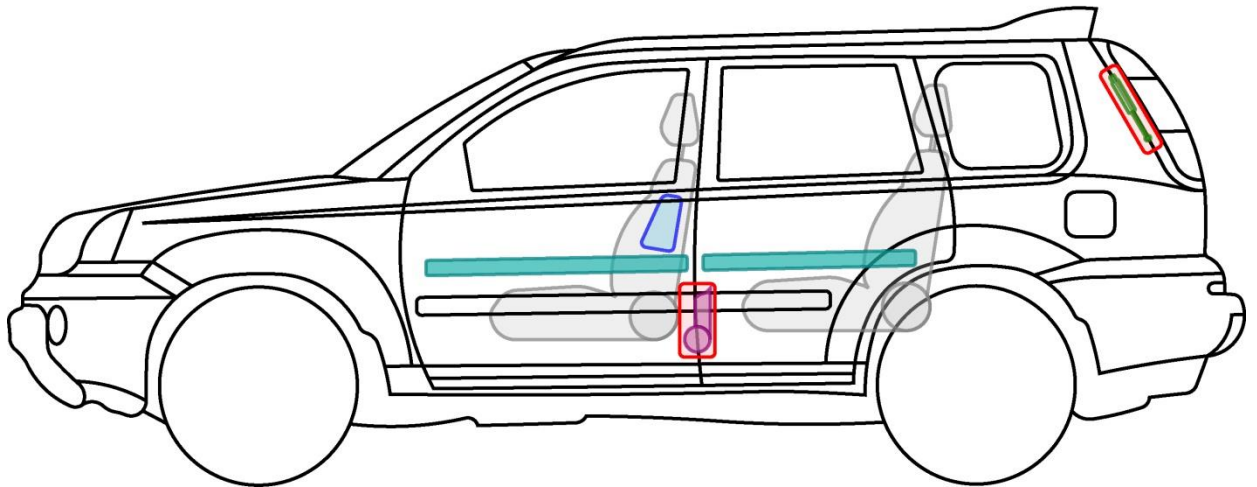
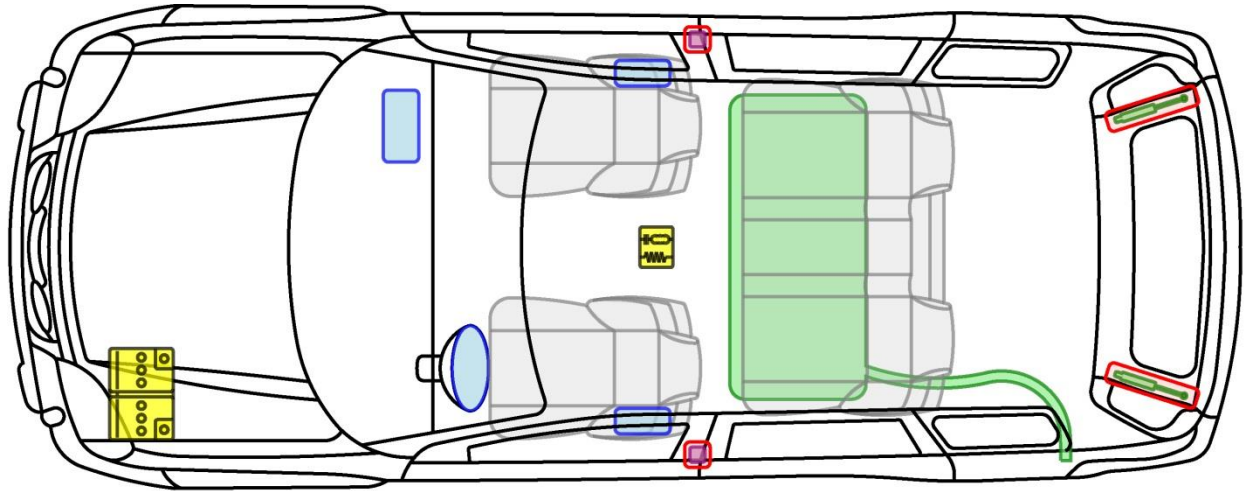

X-TRAIL

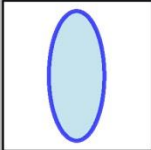
Typ: T30, 2001-2007

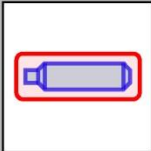

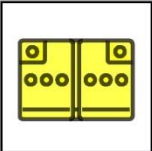
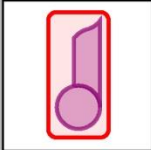
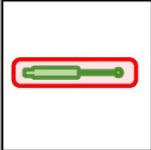
Legende

| | | | | | |
|---|-------------------|---|----------------------------|--|---------------------|
|  | Airbag |  | Karosserie- verstärkung |  | Steuergerät |
|  | Gas- generator |  | Überroll- schutz |  | Batterie |
|  | Gurt- straffer |  | Gasdruck- dämpfer |  | Kraftstoff- tank |

X-TRAIL



X-TRAIL

Typ: T31, 2007-2014

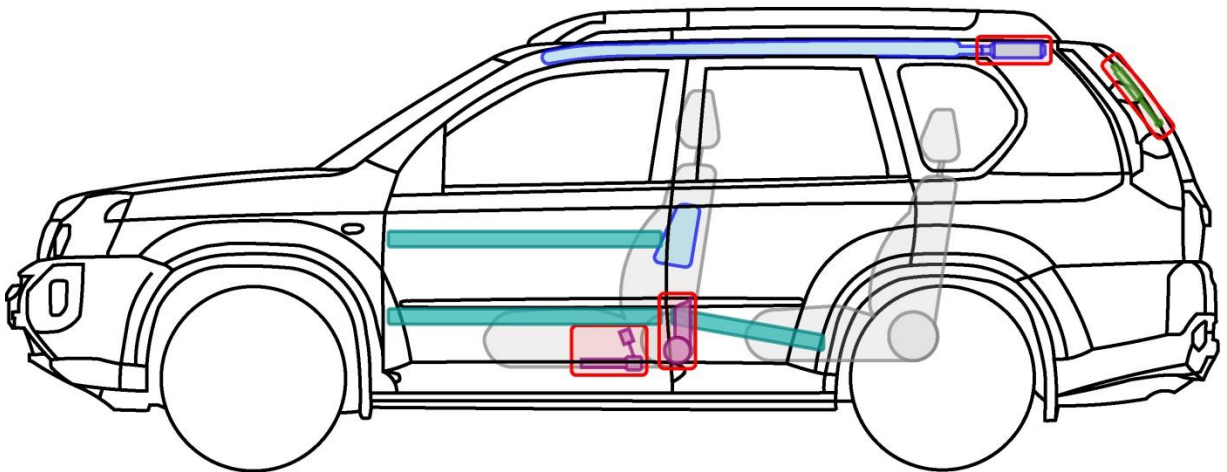
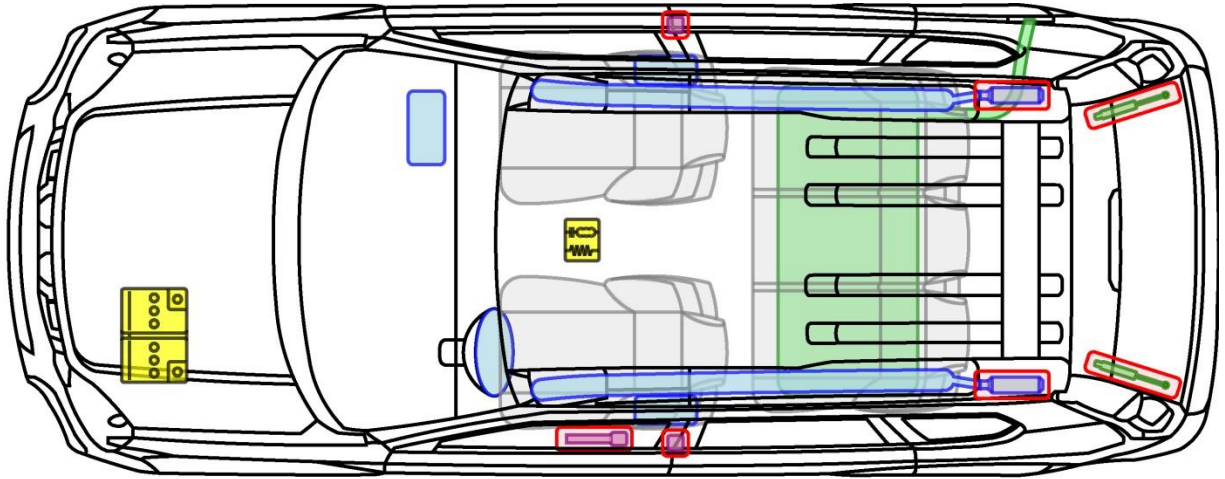

Legende

| | | | | | |
|--|-------------------|--|----------------------------|--|---------------------|
| | Airbag | | Karosserie- verstärkung | | Steuergerät |
| | Gas- generator | | Überroll- schutz | | Batterie |
| | Gurt- straffer | | Gasdruck- dämpfer | | Kraftstoff- tank |

X-TRAIL







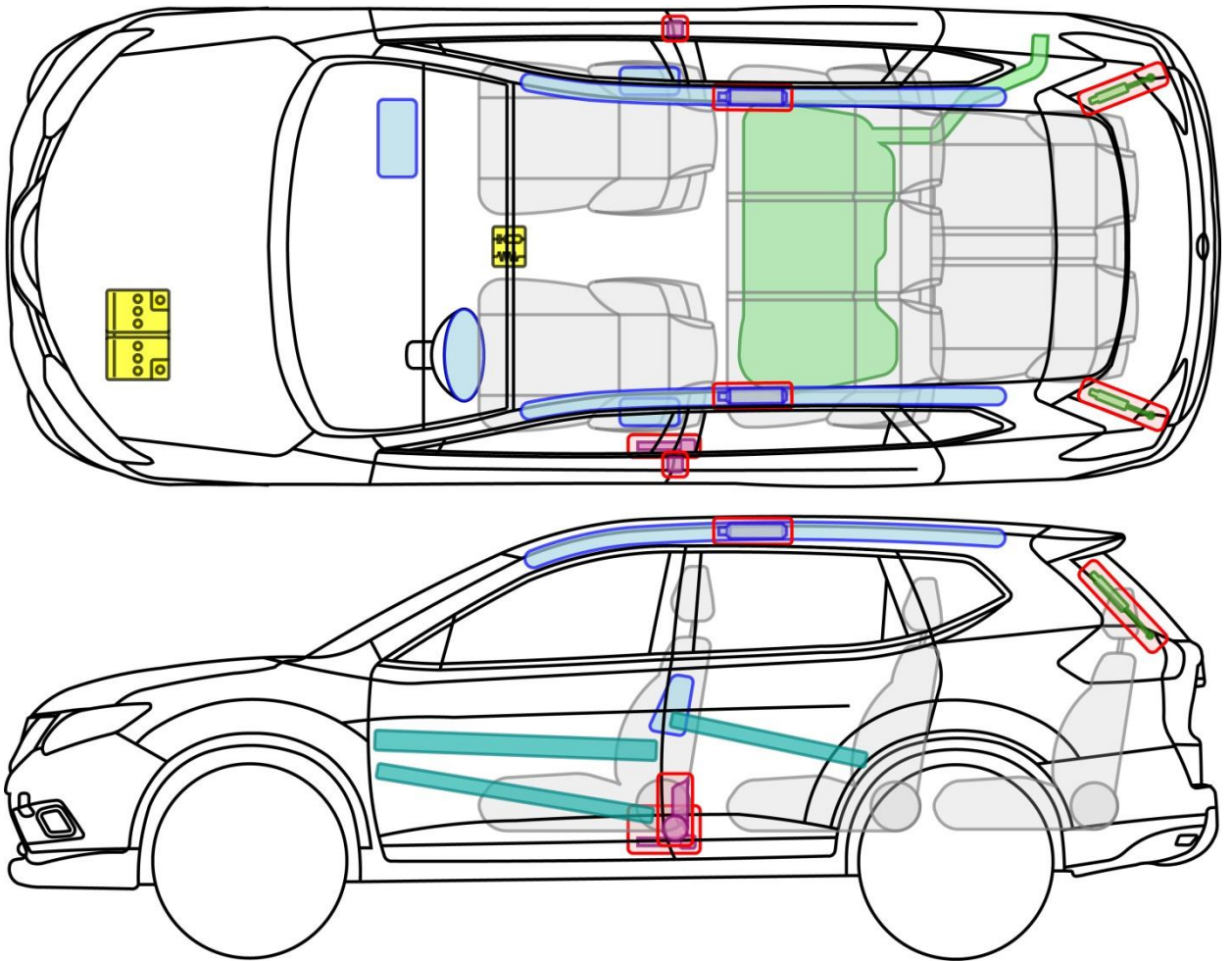

X-TRAIL

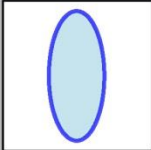
Typ: T32, 2014-

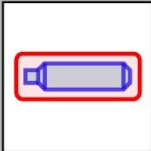

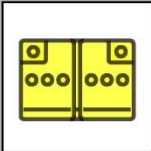
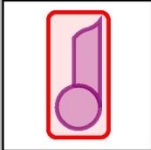
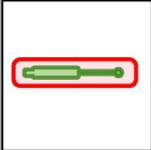
Legende

| | | | | | |
|---|-------------------|---|----------------------------|--|---------------------|
|  | Airbag |  | Karosserie- verstärkung |  | Steuergerät |
|  | Gas- generator |  | Überroll- schutz |  | Batterie |
|  | Gurt- straffer |  | Gasdruck- dämpfer |  | Kraftstoff- tank |

X-TRAIL